

Mini Hi-Fi Component System

Operating Instructions

Owner's Record

The model and serial numbers are located on the rear panel. Record the serial number in the space provided below. Refer to them whenever you call upon your Sony dealer regarding this product.

Model No. _____ Serial No. _____



*MHC-RXD5/R550
MHC-GRX30/GRX30J*

WARNING

To prevent fire or shock hazard, do not expose the unit to rain or moisture.

To avoid electrical shock, do not open the cabinet. Refer servicing to qualified personnel only.

Do not install the appliance in a confined space, such as a bookcase or built-in cabinet.

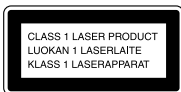

This appliance is classified as a CLASS 1 LASER product. The CLASS 1 LASER PRODUCT MARKING is located on the rear exterior.

NOTICE FOR THE CUSTOMERS IN THE U.S.A.

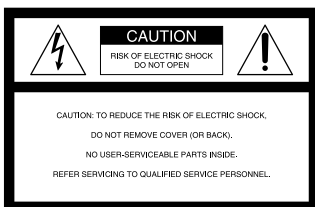

This symbol is intended to alert the user to the presence of uninsulated "dangerous voltage" within the product's enclosure that may be of sufficient magnitude to constitute a risk of electric shock to persons.



This symbol is intended to alert the user to the presence of important operating and maintenance (servicing) instructions in the literature accompanying the appliance.

CAUTION

The use of optical instruments with this product will increase eye hazard.

INFORMATION

This equipment has been tested and found to comply with the limits for a Class B digital device, pursuant to Part 15 of the FCC Rules. These limits are designed to provide reasonable protection against harmful interference in a residential installation. This equipment generates, uses, and can radiate radio frequency energy and, if not installed and used in accordance with the instructions, may cause harmful interference to radio communications. However, there is no guarantee that interference will not occur in a particular installation. If this equipment does cause harmful interference to radio or television reception, which can be determined by turning the equipment off and on, the user is encouraged to try to correct the interference by one or more of the following measures:

- Reorient or relocate the receiving antenna.
- Increase the separation between the equipment and receiver.
- Connect the equipment into an outlet on a circuit different from that to which the receiver is connected.
- Consult the dealer or an experienced radio/TV technician for help.

CAUTION

You are cautioned that any changes or modifications not expressly approved in this manual could void your authority to operate this equipment.

NOTICE FOR THE CUSTOMERS IN CANADA

CAUTION:

TO PREVENT ELECTRIC SHOCK, DO NOT USE THIS POLARIZED AC PLUG WITH AN EXTENSION CORD, RECEPTACLE OR OTHER OUTLET UNLESS THE BLADES CAN BE FULLY INSERTED TO PREVENT BLADE EXPOSURE.

This stereo system is equipped with the Dolby B-type noise reduction system*.

* Manufactured under license from Dolby Laboratories Licensing Corporation. DOLBY and the double-D symbol  are trademarks of Dolby Laboratories Licensing Corporation.



AЯ46

Table of Contents

Getting Started

Step 1: Hooking up the system	4
Step 2: Setting the time	6
Step 3: Presetting radio stations	7
Saving the power in standby mode.....	9

Basic Operations

Playing a CD	10
Recording a CD	12
Listening to the radio	13
Recording from the radio	14
Playing a tape	15
Recording from a tape	17

The CD Player

Using the CD display	18
Playing the CD tracks repeatedly	19
Playing the CD tracks in random order	20
Programming the CD tracks	21
Playing CDs without interruption	22

The Tape Deck

Recording on a tape manually	23
Recording a CD by specifying track order	24

DJ Effects

Looping part of a CD	26
Flashing part of a CD	26

Sound Adjustment

Adjusting the sound	27
Selecting the audio emphasis	28
Changing the spectrum analyzer display	29
Selecting the surround effect	29

Other Features

Using the Radio Data System (RDS)*. ..	30
Singing along: Karaoke	32
Falling asleep to music	34
Waking up to music	34
Timer-recording radio programs	36

Optional Components

Connecting audio components	37
Connecting a VCR	38
Connecting external antennas	39

Additional Information

Precautions	40
Troubleshooting	41
Specifications	44
Index	46

* European model only

Step 1: Hooking up the system

Do the following procedure **1** to **4** to hook up your system using the supplied cords (for European model only) and accessories.

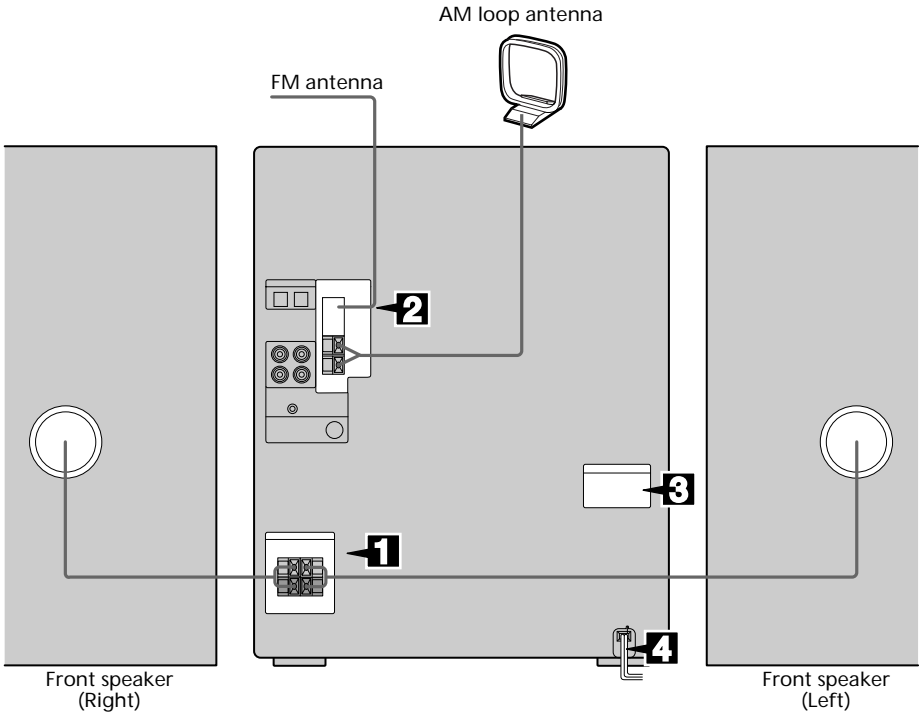

1 Connect the speakers.

Connect the speaker cords of front speakers to the SPEAKER jacks as below.

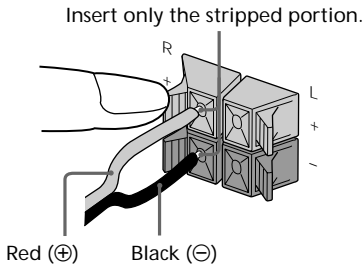

Notes

- Keep the speaker cords away from the antennas to prevent noise.
- The type of speakers supplied varies according to the model you purchased (see "Specifications" on page 44).

- 2** Connect the FM/AM antennas.
Set up the AM loop antenna, then connect it.
Jack type ①

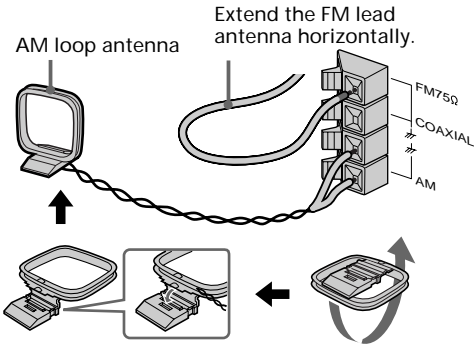

Jack type ②

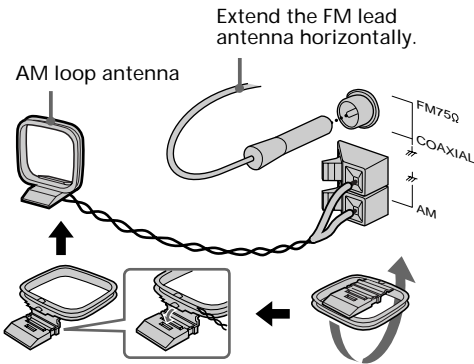

- 3** For models with a voltage selector, set **VOLTAGE SELECTOR** to position of your local power line voltage.

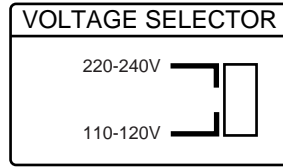

- 4** Connect the power cord to a wall outlet.

The demonstration appears in the display. When you press | / ⏻, the system turns on and the demonstration automatically ends.

If the supplied adaptor on the plug does not fit your wall outlet, detach it from the plug (only for model equipped with an adaptor).

To connect optional components

See page 37.

To deactivate the demonstration

When you set the time (see "Step 2: Setting the time"), the demonstration is deactivated.

To activate/deactivate the demonstration again, press DISPLAY (for MHC-RXD5/R550) or DEMO (STANDBY) (for MHC-GRX30/GRX30J) while the system is off.

continued

Step 1: Hooking up the system (continued)

To attach the front speaker pads

Attach the supplied front speaker pads to the bottom of the speakers to stabilize the speakers and prevent them from slipping.

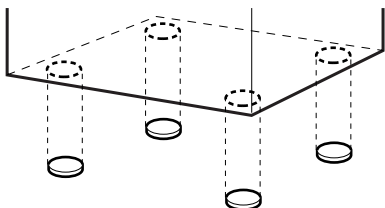

Inserting two size AA (R6) batteries into the remote

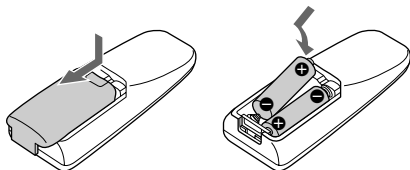

Tip

With normal use, the batteries should last for about six months. When the remote no longer operates the system, replace both batteries with new ones.

Note

If you do not use the remote for a long period of time, remove the batteries to avoid possible damage from battery leakage.

When carrying this system

Do the following to protect the CD mechanism.

- 1 Press **FUNCTION** repeatedly until "CD" appears in the display.
- 2 Hold down **LOOP** and press **| / ⏻** so that "LOCK" appears in the display.

Step 2: Setting the time

You must set the time before using the timer functions.

The clock is on a 24-hour system for the European model and a 12-hour system for other models.

The 24-hour system model is used for illustration purposes.

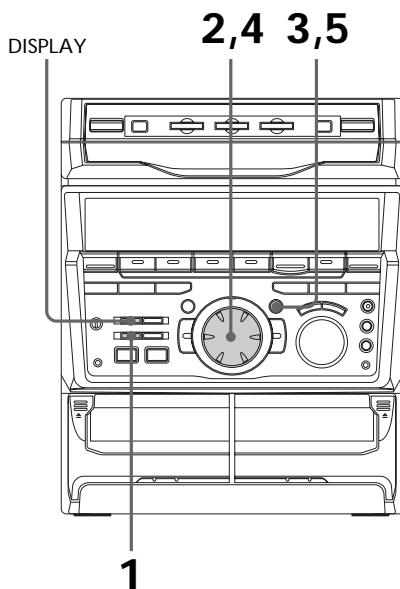

-
- 1 Press **CLOCK/TIMER SET**.
The hour indication flashes.



-
- 2 Turn the jog dial to set the hour.

-
- 3 Press **ENTER/NEXT**.
The minute indication flashes.

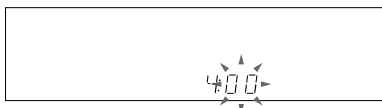

-
- 4 Turn the jog dial to set the minute.

-
- 5 Press **ENTER/NEXT**.
The clock starts working.
-

Tip

If you've made a mistake, start over from step 1.

To change the time

The previous explanation shows you how to set the time while the power is off. To change the time while the power is on, do the following:

- 1 Press **CLOCK/TIMER SET**.
- 2 Turn the jog dial to select **SET CLOCK**.
- 3 Press **ENTER/NEXT**.
- 4 Perform steps 2 through 5 above.

Note

The clock settings are canceled when you disconnect the power cord or if a power failure occurs.

Step 3: Presetting radio stations

You can preset the following number of stations:

- 2 band model: 20 for FM, 10 for AM.
- 3 band model: 20 for FM, 10 for MW and 10 for SW depending on the model you purchased.

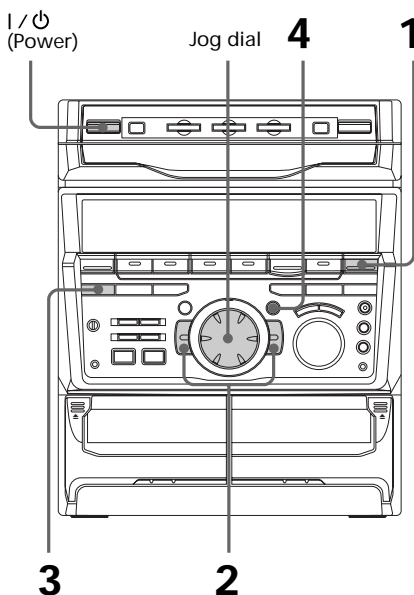

continued

Step 3: Presetting radio stations (continued)

- 1 Press TUNER/BAND repeatedly until the band you want appears in the display.
The bands you can receive vary depending on the model you purchased. Be sure to check which bands you can receive.

Every time you press this button, the band changes as follows:

2 band model:

FM ↔ AM

3 band model:

FM → MW → SW

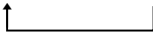

- 2 Press and hold + or - until the frequency indication starts to change, then release.

Scanning stops when the system tunes in a station. "TUNED" and "STEREO" (for a stereo program) appear.



- 3 Press TUNER MEMORY.
A preset number appears in the display. The stations are stored from preset number 1.

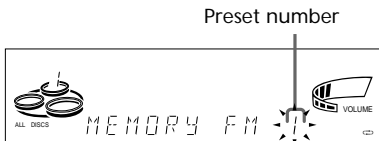

- 4 Press ENTER/NEXT.
The station is stored.
- 5 Repeat steps 1 to 4 to store other stations.

To tune in a station with a weak signal

Press + or - repeatedly to tune in the station manually.

To set another station to the existing preset number

Start over from step 1. After step 3, turn the jog dial to select the preset number you want to store the other station.

You can add a new preset number after the last preset number.

To erase the preset station

- 1 Hold down TUNER MEMORY until a preset number appears in the display.

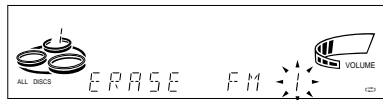

- 2 Turn the jog dial to select the preset number you want to erase.
Select "ALL ERASE" when you want to erase all the preset stations.
- 3 Press ENTER/NEXT.
"COMPLETE" appears.

When you erase a preset number, the preset number decreases by one and all preset numbers following the erased one are renumbered.

To change the AM tuning interval (Except for the European and Middle Eastern models)

The AM tuning interval is factory set to 9 kHz (10 kHz in some areas). To change the AM tuning interval, tune in any AM station first, then turn off the power. While holding down the ENTER/NEXT button, turn the power back on. When you change the interval, AM preset stations will be erased. To reset the interval, repeat the same procedure.

Tip

The preset stations are retained for half a day even if you unplug the power cord or if a power failure occurs.

Saving the power in standby mode

(For European and North American models only)

You can lower the power consumption to minimum (Power Saving Mode) and save energy in standby mode.

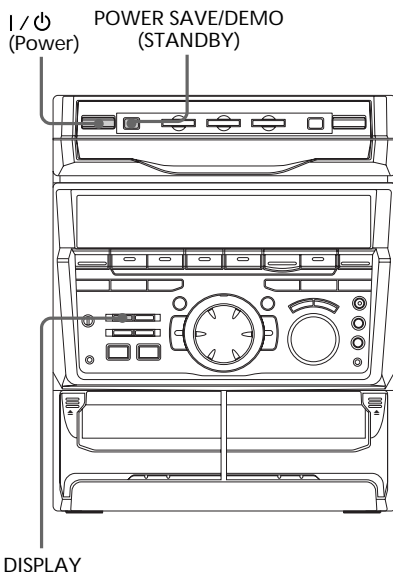

Tips

- Each time you press POWER SAVE/DEMO (STANDBY) in the Power Saving Mode, the display switches between the Power Saving Mode and the demo mode.
- I / ⏻ indicator and timer indicator (when the timer is set) light up even in the Power Saving Mode.
- The timer works in the Power Saving Mode.

Notes

- You cannot set the time in the Power Saving Mode.
- One Touch Play function does not work in the Power Saving Mode.

To cancel the Power Saving Mode

Press DISPLAY.

The clock display appears.

➔ Press POWER SAVE/DEMO (STANDBY) when the power is off (during demo or clock display mode).

The system switches to the Power Saving Mode and the demo or clock display disappears. The system is turned on/off by pressing I / ⏻.

Playing a CD

— Normal play

You can play up to three CDs in a row.

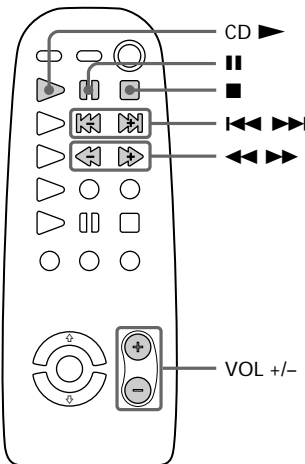
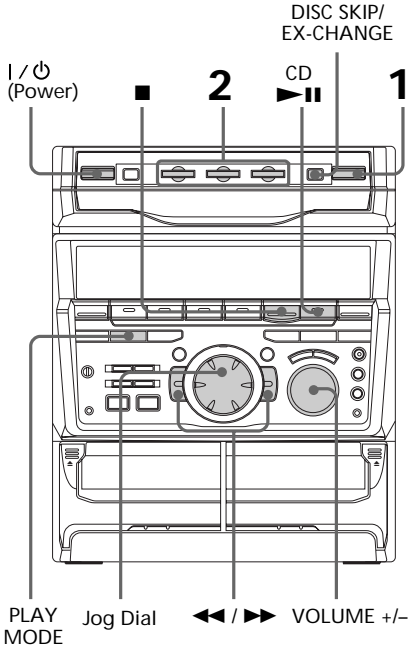

- 1 Press and place up to two CDs on the disc tray.

If a disc is not placed properly it will not be recognized.

With the label side up. When you play a CD single, place it on the inner circle of the tray.



To insert a third disc, press DISC SKIP/EX-CHANGE to rotate the disc tray.

- 2 Press one of the DISC 1~3 buttons.

The disc tray closes and play starts.

If you press CD ▶|| (or CD ▶ on the remote) when the disc tray is closed, play starts from the CD loaded on the tray whose button is lit green.

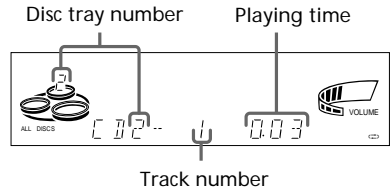

To	Do this
Stop play	Press ■.
Pause	Press CD ► (on the remote). Press again to resume play.
Select a track	During play or pause, turn the jog dial clockwise (to go forward) or counterclockwise (to go back) and release it when you reach the desired track. (Or press ► (to go forward) or ◄◄ (to go back) on the remote.)
Find a point in a track	Press and hold down ►► or ◄◄ during play and release it at the desired point.
Select a CD in stop mode	Press a DISC 1~3 button or DISC SKIP/EX-CHANGE.
Play only the CD you have selected	Press PLAY MODE repeatedly until "1 DISC" appears.
Play all CDs	Press PLAY MODE repeatedly until "ALL DISCS" appears.
Remove the CD	Press ☰.
Exchange other CDs while playing	Press DISC SKIP/EX-CHANGE.
Adjust the volume	Turn VOLUME +/- (or press VOL +/- on the remote).

Tips

- Pressing CD ►|| when the power is off automatically turns the power on and starts CD playback if there is a CD in the tray (One Touch Play). When the system is in the Power Saving Mode, the One Touch Play function does not work.
- You can switch from another source to the CD player and start playing a CD just by pressing CD ►|| or the DISC 1~3 buttons (Automatic Source Selection).
- If there is no CD in the player, "CD NO DISC" appears in the display.
- When a disc tray holding a CD is selected (or playing), the DISC 1~3 button for that tray lights green. When a disc tray holding a CD is not selected, the DISC 1~3 button for that tray lights orange. When all disc trays are empty, the DISC 1~3 buttons all light green.

Recording a CD

— CD Synchro Recording

The CD SYNC button lets you record from a CD to a tape easily. You can use TYPE I (normal) or TYPE II (CrO2) tapes. The recording level is adjusted automatically.

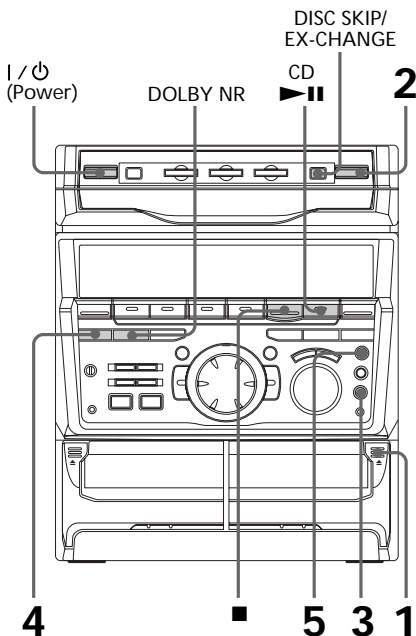

- 1 Press and insert a blank tape into deck B.

With the side you want to record facing forward

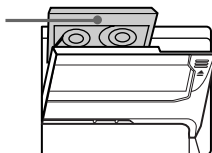

- 2 Press and place a CD.

Then press again to close the disc tray.

If the indicator for the tray you want to record is not lit green, press DISC SKIP/ EX-CHANGE repeatedly so that it lights green.

With the label side up. When you play a CD single, place it on the inner circle of the tray.



- 3 Press CD SYNC.

Deck B stands by for recording and the CD player stands by for playback. The indicator on TAPE B (for front side) lights up.

- 4 Press DIRECTION repeatedly to select to record on one side. Select (or RELAY) to record on both sides.

- 5 Press REC PAUSE/START. Recording starts.

To stop recording

Press .

Tips

- If you want to record from the reverse side, press TAPE B to light its indicator after pressing CD SYNC.
- When you record on both sides, be sure to start from the front side. If you start from the reverse side, recording stops at the end of the reverse side.
- When you want to reduce the hiss noise in low-level high-frequency signals, press DOLBY NR so that "DOLBY NR" appears after pressing CD SYNC.

Note

You cannot listen to other sources while recording.

Listening to the radio

-- Preset Tuning

Preset radio stations in the tuner's memory first (see "Step 3: Presetting radio stations").

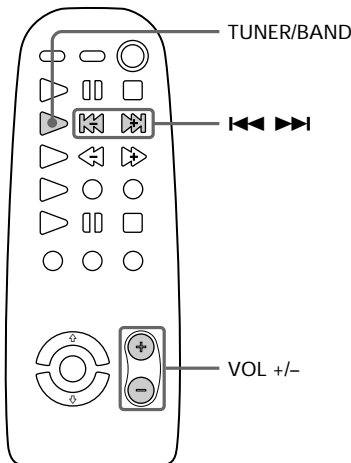
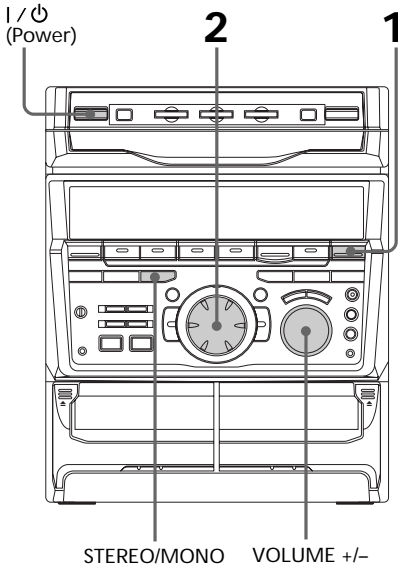

- 1 Press TUNER/BAND repeatedly until the band you want appears in the display.

The bands you can receive vary depending on the model you purchased. Be sure to check which bands you can receive.

Every time you press the button, the band changes as follows:

2 band model:

FM ↔ AM

3 band model:

FM → MW → SW

- 2 Turn the jog dial (or press ◀◀ or ▶▶ on the remote) to tune in the desired preset station.

Turn counter-clockwise (or press ◀◀ on the remote) for lower preset numbers.

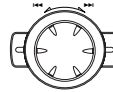

Turn clockwise (or press ▶▶ on the remote) for higher preset numbers.

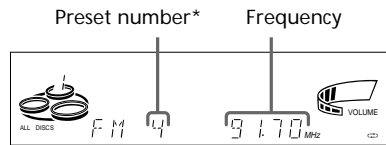

* When only one station is preset, "ONE PRESET" appears in the display.

To	Do this
Turn off the radio	Press I / ⏻.
Adjust the volume	Turn VOLUME +/- (or press VOL +/- on the remote).

continued

Listening to the radio (continued)

To listen to non-preset radio stations

Use manual or automatic tuning in step 2. For manual tuning, press + or - (▶▶ or ◀◀ on the remote) repeatedly. For automatic tuning, press and hold + or - (▶▶ or ◀◀ on the remote).

Tips

- Pressing TUNER/BAND when the power is off automatically turns the power on and tunes to the last received station (One Touch Play). When the system is in the Power Saving Mode, the One Touch Play function does not work.
- You can switch from another source to the radio just by pressing TUNER/BAND (Automatic Source Selection).
- When an FM program is noisy, press STEREO/MONO so that "MONO" appears in the display. There will be no stereo effect, but the reception will improve. Press the button again to restore the stereo effect.
- To improve broadcast reception, reorient the supplied antennas.

Recording from the radio

You can record the radio program on a tape by calling up a preset station. You can use TYPE I (normal) or TYPE II (CrO₂) tapes. The recording level is automatically adjusted.

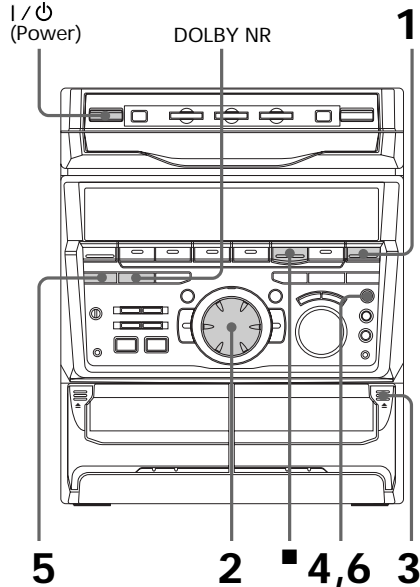

1 Press TUNER/BAND to select the band you want.

2 Turn the jog dial to tune in a preset station.

Turn counter-clockwise for lower preset numbers.

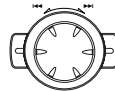

Turn clockwise for higher preset numbers.

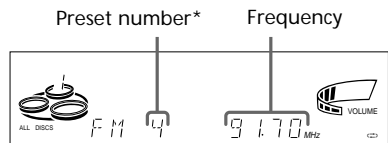



* When only one station is preset, "ONE PRESET" appears in the display.

3 Press  and insert a blank tape into deck B.

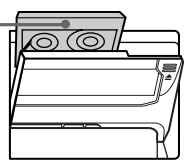
With the side you want to record facing forward



4 Press REC PAUSE/START. Deck B stands by for recording.

5 Press DIRECTION repeatedly to select  to record on one side. Select  (or RELAY) to record on both sides.

6 Press REC PAUSE/START. Recording starts.



To stop recording

Press .

Tips

- If you want to record from the reverse side, press TAPE B  to light its indicator after pressing REC PAUSE/START in step 4.
- When you record on both sides, be sure to start from the front side. If you start from the reverse side, recording stops at the end of the reverse side.
- To record non-preset stations, use + and - in step 2 to tune in the desired station manually.
- When you want to reduce the hiss noise in low-level high-frequency signals, press DOLBY NR so that "DOLBY NR" appears after pressing REC PAUSE/START in step 4.
- If noise is heard while recording from the radio, move the respective antenna to reduce the noise.

Playing a tape

You can use any type of tape, TYPE I (normal), TYPE II (CrO₂) or TYPE IV (metal), since the deck automatically detects the tape type. You can also use the jog dial's AMS* functions to quickly search for songs you want to hear. To select either deck A or B, press DECK A  or DECK B  on the remote.

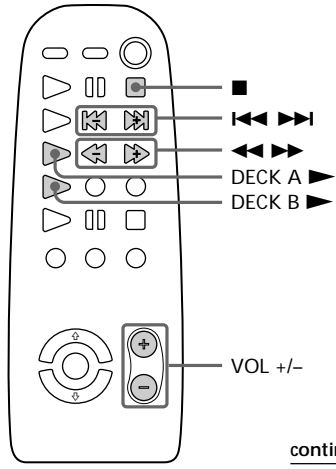
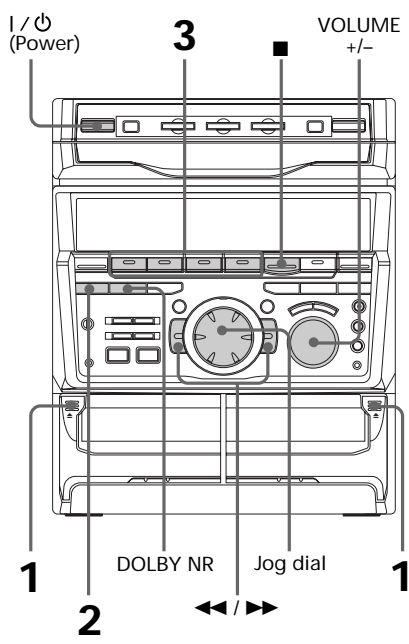

continued

Playing a tape (continued)

- 1 Press **▲** and insert a recorded tape in deck A or B.

With the side you want to play facing forward

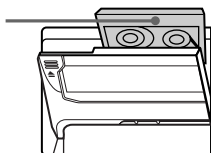

- 2 Press **DIRECTION** repeatedly to select **↔** to play one side. Select **↔*** to play both sides. To play both decks in succession, select **RELAY** (relay play).**

- 3 Press **TAPE A** (or **TAPE B**) **▶** (**DECK A** (or **DECK B**) **▶** on the remote). Press **TAPE A** (or **TAPE B**) **◀** to play the reverse side. (Press **DECK A** (or **DECK B**) **▶** again on the remote to play the reverse side.) The tape starts playing.

- * The deck stops automatically after repeating the sequence five times.
- ** Relay play always follows the following sequence:
Deck A (front side), Deck A (reverse side), Deck B (front side), Deck B (reverse side).

To	Do this
Stop play	Press ■ .
Fast-forward	Press ◀◀ or ▶▶ .
Rewind	Press ◀◀ or ▶▶ .
Remove the cassette	Press ▲ .
Adjust the volume	Turn VOLUME +/- (or press VOL +/- on the remote).

Tips

- Pressing **TAPE A** (or **TAPE B**) **▶** or **◀** when the power is off automatically turns the power on and starts tape playback if there is a tape in the deck (One Touch Play). When the system is in the Power Saving Mode, the One Touch Play function does not work.
- You can switch from another source to the tape deck just by pressing **TAPE A** (or **TAPE B**) **▶** or **◀** (Automatic Source Selection).
- When you want to reduce the hiss noise in low-level high-frequency signals, press **DOLBY NR** so that "DOLBY NR" appears.

Searching for the beginning of a track (AMS*)

During playback, turn the jog dial the same direction as the **◀** or **▶** indicator to go forward. Turn the opposite direction to go back. (Or press **◀◀** or **▶▶** on the remote.)

The search direction, + (forward) or - (back), and number of songs being skipped (1~9) appear in the display.

Example: searching forward 2 songs

T A P E A : : : + 2

* AMS (Automatic Music Sensor)

Notes

The AMS function may not operate correctly under the following circumstances:

- When the unrecorded space between songs is less than 4 seconds long.
- If completely different information is recorded on the left and right channels.
- When there are continuous sections of extremely low level or low frequency sound (like those of a baritone sax).
- When the unit is placed near a television. (In this case, we recommend moving the unit farther away from the television or turning off the television.)

Recording from a tape

— High-speed Dubbing

You can use TYPE I (normal) or TYPE II (CrO₂) tapes. The recording level is automatically adjusted.

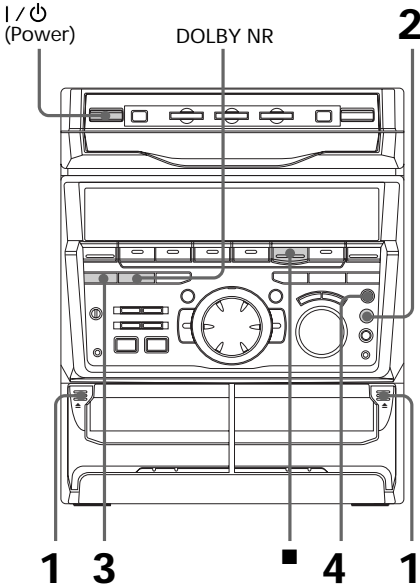

- 1 Press and insert a recorded tape in deck A and a blank tape in deck B.

With the side you want to play/record facing forward

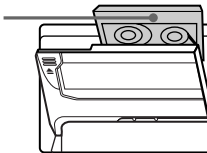

- 2 Press HI-DUB.
Deck B stands by for recording.

- 3 Press DIRECTION repeatedly to select to record on one side. Select (or RELAY) to record on both sides.

- 4 Press REC PAUSE/START.
Dubbing starts.

To stop dubbing

Press .

Tips

- When you dub on both sides, start recording from the front side. If you record from the reverse side, recording stops at the end of the reverse side.
- If you set DIRECTION to when the tapes you use have different lengths, the tape in each deck reverses independently. If you select RELAY, the tapes in both decks reverse together.
- You don't have to set DOLBY NR, since the tape in deck B is automatically recorded in the same state as the tape in deck A.

Using the CD display

You can check the remaining time of the current track or that of the CD.

When a CD TEXT disc is loaded, you can check the information stored on the disc, such as the titles or artist names.

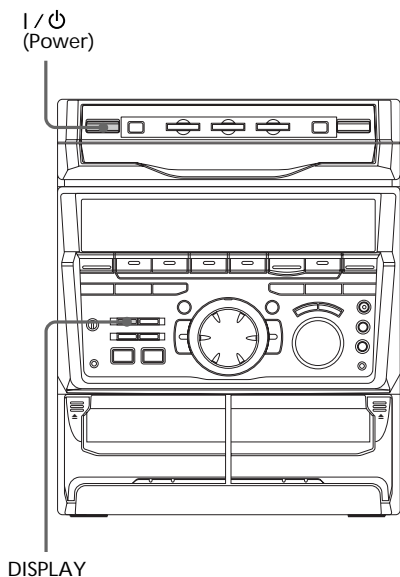

➔ Press DISPLAY.

Each time you press the button during normal playback or in the stop mode, the display changes as follows:

During normal playback

- Playing time on the current track
- ↓
- Remaining time on the current track
- ↓
- Remaining time on current CD (1 DISC mode) or "--:--" display (ALL DISCS mode)
- ↓
- Title name of the current track*
- ↓
- Clock display (for eight seconds)
- ↓
- Effect name or "EFFECT ON (OFF)"

In the stop mode

- Title name of the CD*
- ↓
- Artist information*
- ↓
- Total number of tracks and total playing time
- ↓
- Clock display (for eight seconds)
- ↓
- Effect name or "EFFECT ON (OFF)"

* With CD TEXT discs only (certain characters cannot be displayed). When the CD contains more than 20 tracks, CD TEXT is not displayed from track 21 on.

Playing the CD tracks repeatedly

-- Repeat Play

This function lets you repeat a single CD or all CDs in normal play, Shuffle Play and Program Play.

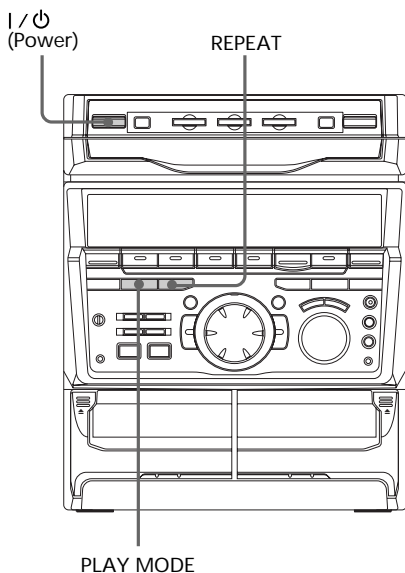

➔ Press REPEAT during playback until "REPEAT" appears in the display.

Repeat Play starts. Do the following procedure to change the repeat mode.

To repeat	Press
All the tracks on the current CD	PLAY MODE repeatedly until "1 DISC" appears in the display.
All the tracks on all CDs	PLAY MODE repeatedly until "ALL DISCS" appears in the display.
Only one track	REPEAT repeatedly until "REPEAT 1" appears in the display while playing the track you want to repeat.

To cancel Repeat Play

Press REPEAT so that "REPEAT" or "REPEAT 1" disappears from the display.

Playing the CD tracks in random order

-- Shuffle Play

You can play all the tracks on one CD or all CDs in random order.

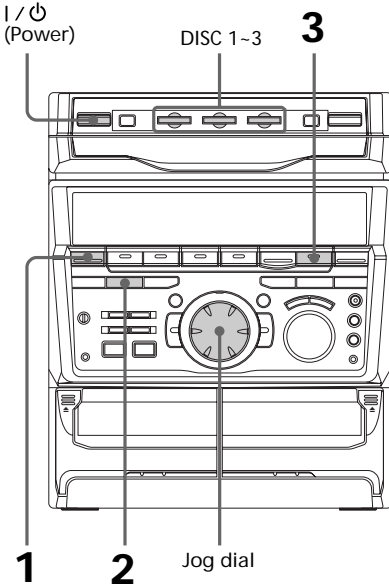

-
- 1** Press FUNCTION repeatedly until “CD” appears in the display, then place a CD.

 - 2** Press PLAY MODE repeatedly until “1 DISC SHUFFLE ” or “ALL DISCS SHUFFLE” appears in the display. “ALL DISCS” shuffles all the CDs in the player. “1 DISC” shuffles the CD whose DISC indicator is green.

 - 3** Press CD ►||. All the tracks play in random order.
-

To cancel Shuffle Play

Press PLAY MODE repeatedly until “SHUFFLE” or “PROGRAM” disappears from the display. The tracks continue playing in their original order.

To select a desired CD

Press DISC 1~3.

Tips

- You can start Shuffle Play during normal play by pressing PLAY MODE repeatedly to select “SHUFFLE”.
- To skip a track, turn the jog dial clockwise (or press ►|| on the remote).

Programming the CD tracks

-- Program Play

You can make a program of up to 32 tracks from all the CDs in the order you want them to be played.

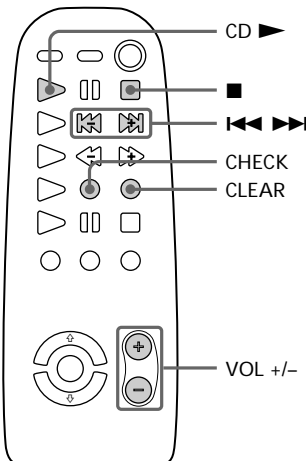
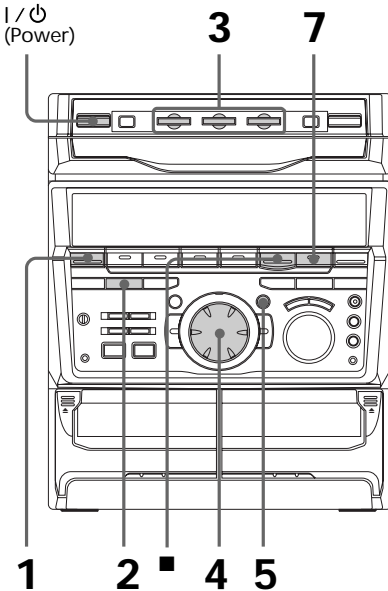

1 Press FUNCTION repeatedly until "CD" appears in the display, then place a CD.

2 Press PLAY MODE repeatedly until "PROGRAM" appears in the display.

3 Press one of the DISC 1~3 buttons to select a CD.

4 Turn the jog dial until the desired track appears in the display.

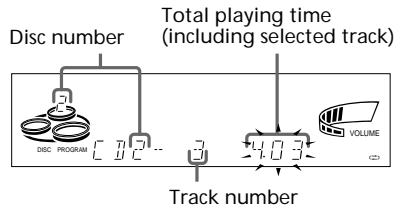

5 Press ENTER/NEXT.
The track is programmed. The program step number appears, followed by the total playing time.

6 To program additional tracks, repeat steps 3 to 5.
Skip step 3 to select tracks from the same disc.

7 Press CD ► ||.
All the tracks play in the order you selected.

continued

Programming the CD tracks (continued)

To cancel Program Play

Press PLAY MODE repeatedly until "PROGRAM" or "SHUFFLE" disappears from the display.

To	Press
Check the program	CHECK on the remote repeatedly. After the last track, "CHECK END" appears.
Clear a track from the end	CLEAR on the remote in stop mode.
Clear a specific track	CHECK on the remote repeatedly until the number of the track to be erased lights up, then press CLEAR.
Add a track to the program	1 Select the disc tray with a DISC 1~3 button. 2 Select the track by turning the jog dial. 3 Press ENTER/NEXT.
Clear the entire program	■ once in stop mode or twice while playing.

Tips

- The program you made remains in the CD player even after it has been played back. Press CD ►|| to play the same program again.
- If "--:--" appears instead of the total playing time during programming, this means:
 - you have programmed a track number which exceeds 20.
 - the total playing time has exceeded 100 minutes.

Playing CDs without interruption

-- Non-Stop Play

You can play CDs without pausing between tracks.

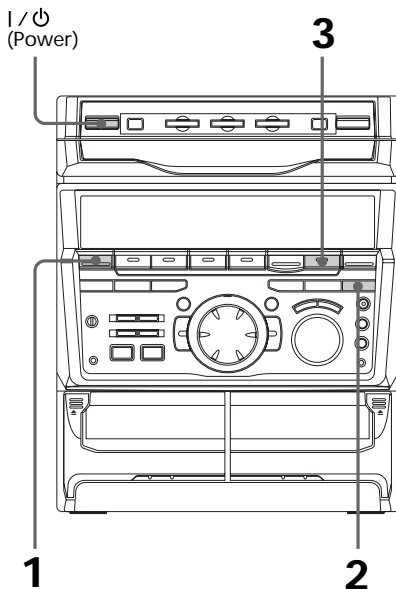

1 Press FUNCTION repeatedly until "CD" appears in the display, then place a CD.

2 Press NON-STOP to light the indicator. "NON-STOP PLAY" appears in the display.

3 Press CD ►||.

To cancel Non-Stop Play

Press NON-STOP so that the indicator goes out and "NON-STOP OFF" appears in the display.

Recording on a tape manually

You can record from CD, tape, or radio as you like. For example, you can record just the songs you want or record from the middle of the tape. The recording level is adjusted automatically.

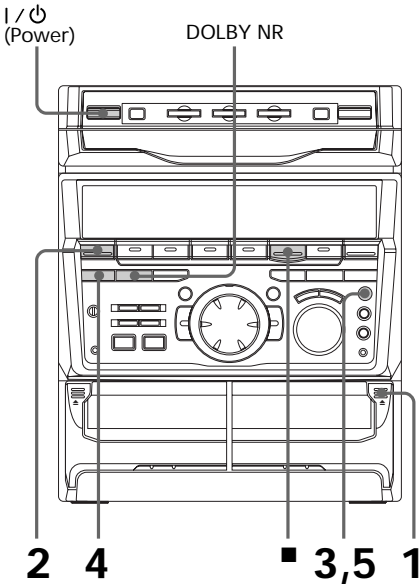

- 1** Insert a blank tape into deck B.
- 2** Press **FUNCTION** repeatedly until the source you want to record (e.g., CD) appears.
- 3** Press **REC PAUSE/START**. Deck B stands by for recording. The indicator on **TAPE B** (for front side) lights up.

- 4** Press **DIRECTION** repeatedly to select \rightleftarrows to record on one side. Select \leftrightarrow (or **RELAY**) to record on both sides.

- 5** Press **REC PAUSE/START**. Recording starts.

- 6** Start playing the source to be recorded.

To	Press
Stop recording	■
Pause recording	REC PAUSE / START.

Tips

- If you want to record from the reverse side, press **TAPE B** \blacktriangleleft to light its indicator after pressing **REC PAUSE/START** in step 3.
- When you want to reduce the hiss noise in low-level high-frequency signals, press **DOLBY NR** so that "DOLBY NR" appears after pressing **REC PAUSE/START** in step 3.
- When recording from a CD, you can use the jog dial to select tracks during rec pause mode (after pressing **REC PAUSE/START** in step 3 and before pressing **REC PAUSE/START** in step 5).

Recording a CD by specifying track order

— Program Edit

You can record tracks from all the CDs in the order you want. When programming, make sure the playing times for each side do not exceed the length of one side of the tape.

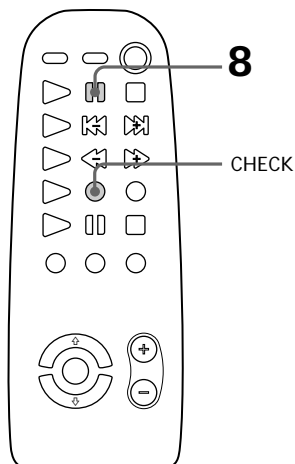
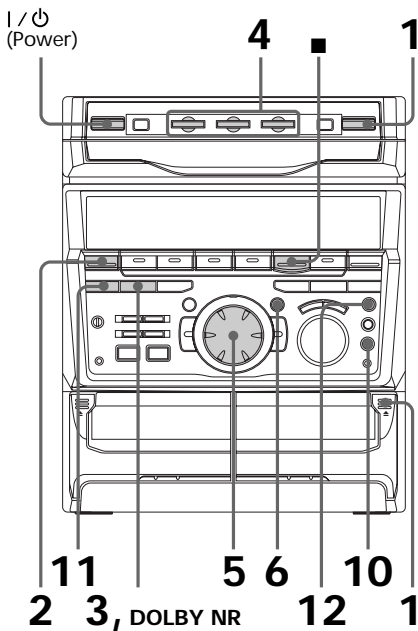

- 1 Place a CD and insert a blank tape into deck B.
- 2 Press FUNCTION repeatedly until “CD” appears in the display.
- 3 Press PLAY MODE repeatedly until “PROGRAM” appears in the display.
- 4 Press one of the DISC 1~3 buttons to select a CD.

- 5 Turn the jog dial until the desired track appears in the display.

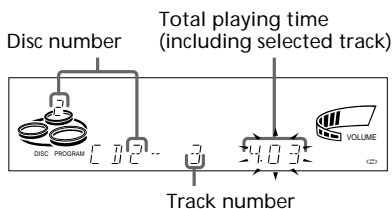

- 6 Press ENTER/NEXT.
The track is programmed. The program step number appears, followed by the total playing time.
- 7 To program additional tracks to be recorded on side A, repeat steps 4 to 6.
Skip step 4 to select tracks from the same disc.

- 8 Press **||** on the remote to insert a pause at the end of side A.
“P” appears in the display and the total playing time resets to “0.00” in the display.

9 Repeat steps 5 and 6 for tracks from the same disc or steps 4 to 6 for tracks from another disc to program the remaining tracks to be recorded on side B.

10 Press CD SYNC.
Deck B stands by for recording and the CD player stands by for playback. The indicator on TAPE B ► (for front side) lights up.

11 Press DIRECTION repeatedly to select ⇄ to record on one side. Select ⇄ (or RELAY) to record on both sides.

12 Press REC PAUSE/START.
Recording starts.

To stop recording

Press ■.

To check the order

Press CHECK on the remote repeatedly. After the last track, "CHECK END" appears.

To cancel Program Edit

Press PLAY MODE repeatedly until "PROGRAM" or "SHUFFLE" disappears from the display.

Tip

When you want to reduce the hiss noise in low-level high-frequency signals, press DOLBY NR so that "DOLBY NR" appears after pressing CD SYNC.

Selecting tape length automatically

—Tape Select Edit

You can check the most suitable tape length for recording a CD. Do the following steps before recording.

1 Insert a CD.

2 Press FUNCTION repeatedly until "CD" appears in the display.

3 Press EDIT once, so that "EDIT" flashes.

The required tape length for the currently selected CD appears, followed by the total playing time for side A and side B respectively.

Notes

- You cannot use Tape Select Edit for discs containing over 20 tracks.
- You cannot use this function after programming. In order to use this function, you must first cancel the program by pressing PLAY MODE repeatedly until "PROGRAM" or "SHUFFLE" disappears from the display.

Looping part of a CD

— Loop

With the loop function, you can repeat part of a CD during playback. This lets you create original recordings.

I / ⏻
(Power)

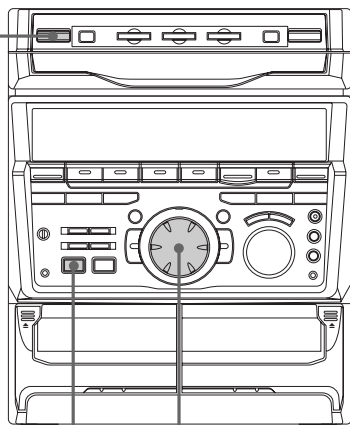

LOOP Jog dial

➔ Press and hold LOOP during playback at the point you want to start the Loop function, and release to resume normal play.

To adjust the loop length

Turn the jog dial while holding LOOP (or press FILE SELECT **↑** or **↓** while holding LOOP on the remote) to select different loop lengths (LOOP 1~20).

Flashing part of a CD

— Flash

With the flash function, you can “flash” the CD sound during playback. This lets you create original recordings.

I / ⏻
(Power)

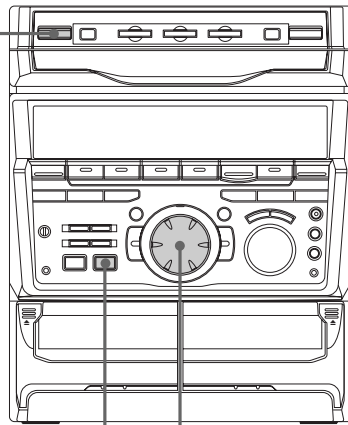

FLASH Jog dial

➔ Press and hold FLASH during playback at the point you want to start the Flash function, and release to resume normal play.

To adjust the flash length

Turn the jog dial while holding FLASH (or press FILE SELECT **↑** or **↓** while holding FLASH on the remote) to select different flash lengths (FLASH 1~20).

To use LOOP and FLASH together

Press and hold both LOOP and FLASH at the same time.

Notes



- The loop and flash length cannot be adjusted during this operation. Adjust the loop and flash lengths independently beforehand if necessary.
- To record the loop or flash effect, use the analog MD/VIDEO (AUDIO) OUT connections or this unit's tape deck.

Adjusting the sound

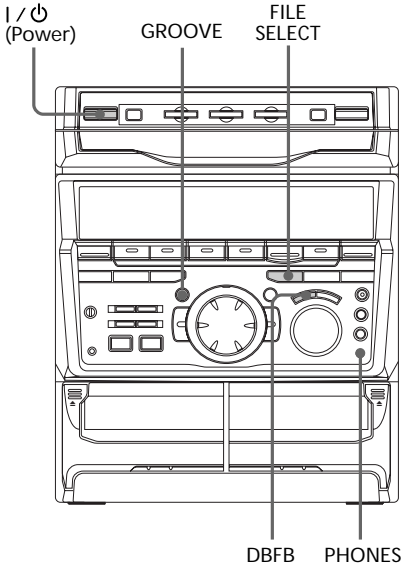
You can reinforce the bass, create a more powerful sound, and listen with headphones.



Notes

- With some songs, the music will sound distorted when you use the DBFB system with the sound effect if the bass is too strong. Set the DBFB to “DBFB  ” or “OFF”, or cancel the sound effect (see page 28).
- Cancelling GROOVE sets DBFB to “DBFB  ” and flattens the equalizer curve. To cancel the DBFB level, press DBFB until the indication disappears.

To listen through the headphones

Connect the headphones to PHONES jack. No sound will come from the speakers.

Note

(except for European model)

If you have connected a super woofer, please note that sound comes from the super woofer even when the headphones are connected. Turn off the power of the super woofer when using headphones.

To reinforce bass (DBFB)

Press DBFB*.

Every time you press the button, the display changes as follows:

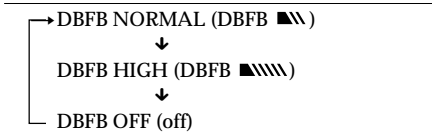

* DBFB = Dynamic Bass Feedback

For a powerful sound (GROOVE)

Press GROOVE. The volume switches to power mode, DBFB is automatically set to full strength, the equalizer curve changes, and the “GROOVE” button lights up. Press GROOVE again to return to the previous volume.

Selecting the audio emphasis

The audio emphasis menu lets you select the sound characteristic according to the sound you are listening to.

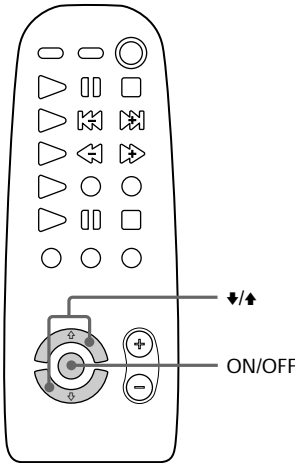
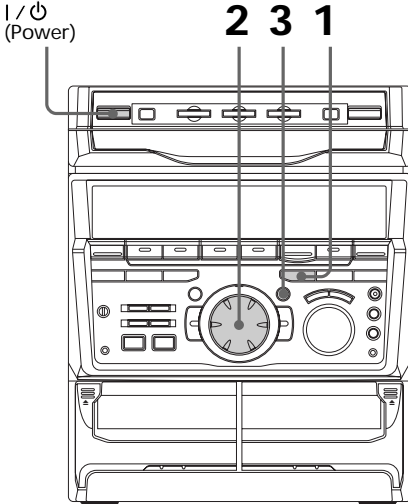

- 1** Press FILE SELECT.
The last effect chosen appears in the display.
- 2** Use the jog dial (or press ↓/↑ on the remote) to select the preset you desire.
The preset name appears in the display. See the chart “Music menu options”.
- 3** Press ENTER/NEXT.

To cancel the effect

Press ON/OFF on the remote repeatedly so that “EFFECT OFF” appears in the display.

Music menu options

“SUR ■■■■” appears if you select an effect with surround effects.

Effect	For
ROCK	Standard music sources
POP	
JAZZ	
DANCE	
SOUL	
ACTION	Soundtracks and special listening situations
ROMANCE	
DRAMA	
SPORTS	
FLAT	Listening without effects

Changing the spectrum analyzer display

You can enjoy changing the display while listening to the music.

I / ⏻
(Power)

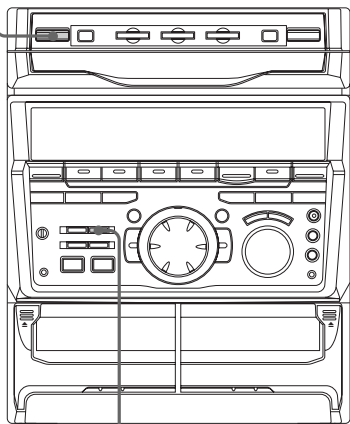

SPECTRUM
ANALYZER

- ➔ Press SPECTRUM ANALYZER.
Every time you press the button, the display changes as follows:

IMAGE PATTERN
↕
NORMAL PATTERN

Selecting the surround effect

You can enjoy the surround effect.

I / ⏻
(Power)

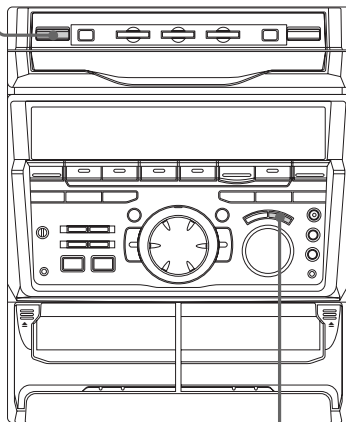

SURROUND

- ➔ Press SURROUND to turn the surround effect on or off.
Every time you press the button, the display changes as follows:

→ SURROUND ON (SUR ■■■■)
↓
→ SURROUND OFF (off)

Note

When you choose other sound effects, the surround effect will be canceled.

Using the Radio Data System (RDS)

(For European model only)

What is the Radio Data System?

Radio Data System (RDS) is a broadcasting service that allows radio stations to send additional information along with the regular program signal. This tuner offers convenient RDS features like station name display and location of stations by program type. RDS is available only on FM stations.*

Note

RDS may not work properly if the station you are tuned to is not transmitting the RDS signal properly or if the signal strength is weak.

* Not all FM stations provide RDS service, nor do they provide the same type of services. If you are not familiar with the RDS system, check with your local radio stations for details on RDS services in your area.

Receiving RDS broadcasts

➔ Simply select a station from the FM band. When you tune in a station that provides RDS services, the station name appears in the display.

To check the RDS information

Each time you press DISPLAY, the display changes as follows:

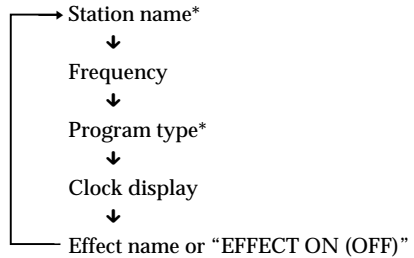

* If the RDS broadcast is not received, the station name and program type may not appear in the display.

Locating a station by program type (PTY)

You can locate a station you want by selecting a program type. The unit tunes in the type of programs currently being broadcast from the RDS stations stored in the tuner's preset memory.

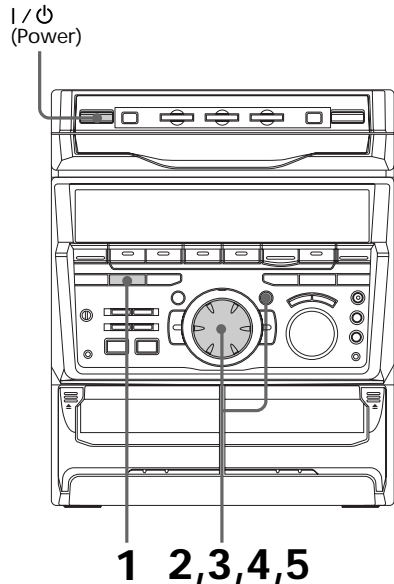

- 1** Press **PTY** while listening to the radio.
- 2** Turn jog dial to select the program type you want. See the “List of program types” section below.
- 3** Press **ENTER/NEXT**.
The unit starts searching the preset RDS stations (“SEARCH” and the selected program type are shown alternately in the display).
When the tuner receives a program, the preset station number flashes.
- 4** Turn jog dial to continue search for the station number you desire.
- 5** Press **ENTER/NEXT** while the preset station number you desire is flashing.

To cancel PTY search

Press **PTY** again.

List of program types (PTY)

NEWS

News programs

AFFAIRS

Topical programs that expand on current news

INFORMATION

Programs about consumer affairs, medical advice, etc.

SPORT

Sports programs

EDUCATION

Educational programs, such as “how-to” programs and advice

DRAMA

Radio plays and serials

CULTURE

Programs about national or regional culture, language and social concerns

SCIENCE

Programs about the natural sciences

VARIED

Programs containing celebrity interviews, panel games, and comedy

POP

Popular music programs

ROCK

Rock music programs

EASY MUSIC

Easy listening (middle of the road music)

L CLASSICAL

Classical music, such as instrumental, vocal, and choral works

S CLASSICAL

Performances of major orchestras, chamber music, opera, etc.

OTHER MUSIC

Music, such as jazz, rhythm and blues, and reggae

WEATHER

Weather information

FINANCE

Stock market reports and tradings, etc.

CHILDREN

Program for children

SOCIAL

Programs about people and the things that affect them

RELIGION

Programs of religious contents

PHONE IN

Programs where members of the public express their views by phone or in a public forum

TRAVEL

Programs about travel. Not for announcements that are located by TP/TA

LEISURE

Programs on recreational activities such as gardening, fishing, cooking, etc.

continued

Using the Radio Data System (RDS) (continued)

JAZZ

Jazz programs

COUNTRY

Country music programs

NATION

Programs featuring the popular music of the country or region

OLDIES

Programs featuring oldies music

FOLK

Folk music programs

DOCUMENTARY

Investigative features

ALARM TEST

Test signal for emergency broadcasts

ALARM-ALARM

Emergency broadcasts

NONE

Any programming not defined above

Note

"NO PTY" appears when the program type that you selected is not currently being broadcast.

Singing along: Karaoke

You can sing along with any stereo CD or tape by turning down the singer's voice. You need to connect an optional microphone.

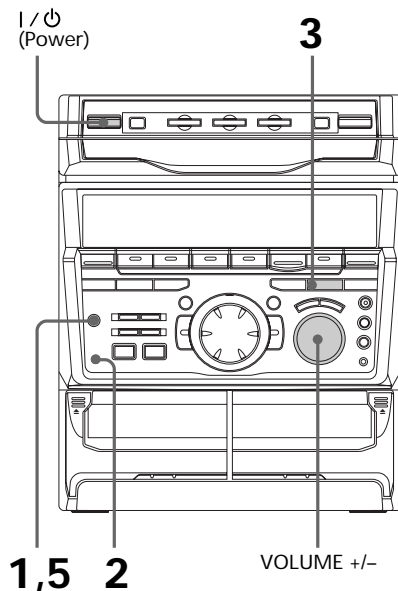

1 Turn MIC LEVEL to 0 to turn down the microphone control level.

2 Connect an optional microphone to MIX MIC.

3 Press KARAOKE PON/MPX repeatedly to obtain the karaoke effect you desire.

Every time you press the button, the display changes as follows:

KARAOKE PON → MPX R → MPX L
└── Effect name or "EFFECT ON (OFF)*" ──┘

* When an audio emphasis is selected, the effect name appears.

The  indicator appears in the display when a karaoke mode is activated.

To sing karaoke with decreasing the vocal level of a CD, select “KARAOKE PON”. To sing karaoke of multiplex CD or tape, select “MPX R” or “MPX L”.

4 Start playing the music and adjust the volume.

5 Adjust the microphone volume by turning MIC LEVEL.

When you are done

Turn MIC LEVEL to 0 and disconnect the microphone from MIX MIC, then press KARAOKE PON/MPX repeatedly so that “” disappears.

Note

With some songs, vocals may not be canceled when you select “KARAOKE PON”.

Mixing and recording sounds

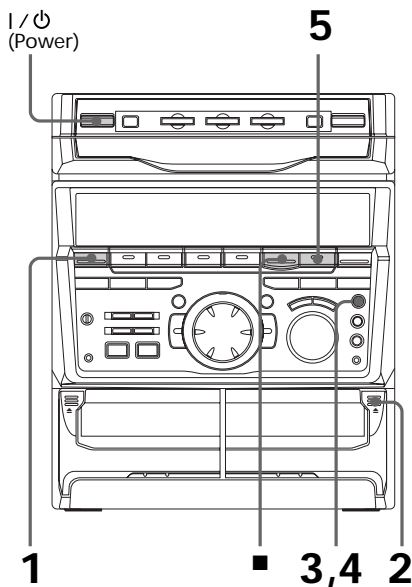



1 Press FUNCTION repeatedly to select the source you desire and set it to pause mode.

2 Do steps 1 to 5 in the “Singing along: Karaoke” section. Then, insert a tape in deck B.

3 Press REC PAUSE/START.

4 Press REC PAUSE/START again. Recording starts.

5 Press CD  to start playing the CD player (or TAPE A  for tape deck A).

Playback starts. Start singing along with the music.

To stop recording

Press .

Tips

- If acoustic feedback (howling) occurs, move the microphone away from the speakers or change the direction of the microphone.
- If you want to record your voice through the microphone only, you can do so by selecting the CD function and not playing a CD.

Notes

- If you press ON/OFF on the remote or press FUNCTION or recall a sound effect, the karaoke mode is canceled.
- The instrumental sound may be reduced as well as the singer's voice when the sound is recorded in monaural.
- The singer's voice may not be reduced when:
 - only a few instruments are playing.
 - a duet is being played.
 - the source has strong echoes or chorus.
 - the singer's voice deviates from the center.
 - the voice on the source is singing in high soprano or tenor.

Falling asleep to music

— Sleep Timer

You can let the system turn off at the preset time, so you can sleep to the music. You can preset the time to be turned off by 10 minutes.

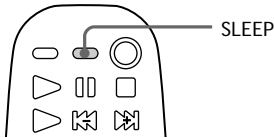

➔ Press **SLEEP** on the remote.

Every time you press the button, the minute display (the turn-off time) changes as follows:

AUTO → 90min → 80min → 70min
→ ... → 10min → OFF → AUTO ...

When you choose “SLEEP AUTO”

The power turns off when the current CD or tape finishes playback (for up to 100 minutes).

To check the remaining time

Press **SLEEP** once.

To change the time to turn off

Select the time you want by pressing **SLEEP**.

To cancel the Sleep Timer function

Press **SLEEP** repeatedly until “SLEEP OFF” appears.

Waking up to music

— Daily Timer

You can wake up to music at a preset time every day. Make sure you have set the clock (see “Step 2: Setting the time”).

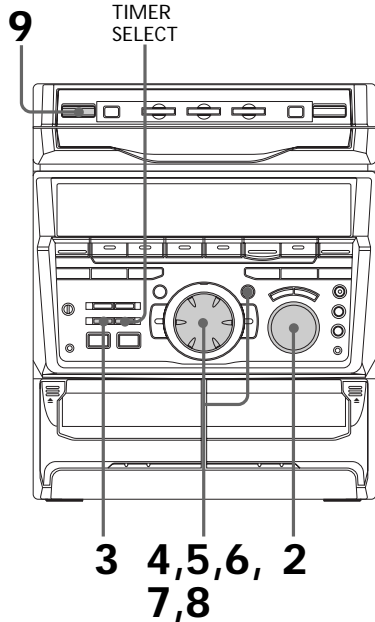

1 Prepare the music source you want to play.

- CD: Insert a CD. To start from a specific track, make a program (see “Programming the CD tracks”).
- Tape: Insert a tape with the side you want to play facing forward.
- Radio: Tune in the preset station you want (see “Step 3: Presetting radio stations”).

2 Adjust the volume.

3 Press **CLOCK/TIMER SET**.
“SET DAILY 1” appears.

-
- 4** Turn jog dial to select “DAILY 1 (or 2)”, then press ENTER/NEXT. “ON” appears and the hour digits flash in the display.



-
- 5** Set the time to start playback. Turn jog dial to set the hour, then press ENTER/NEXT. The minute indication starts flashing.

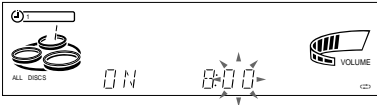

Turn jog dial to set the minute, then press ENTER/NEXT. The hour indication flashes again.

-
- 6** Set the time to stop playback following the above procedure.

-
- 7** Turn jog dial until the music source you want appears. The indications change as follows:

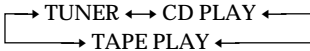

-
- 8** Press ENTER/NEXT. The type of timer (DAILY 1 or DAILY 2), followed by the start time, stop time and the music source, appears, then the original display appears.

-
- 9** Turn off the power.
-

To check the setting

Press TIMER SELECT and turn the jog dial to select the respective mode (DAILY 1 or DAILY 2), then press ENTER/NEXT.

To change the setting, start over from step 1.

To cancel the timer operation

Press TIMER SELECT and turn the jog dial to select “TIMER OFF”, then press ENTER/NEXT.

Tip

The power turns on 15 seconds before the preset time.

Timer-recording radio programs

To timer-record, you must preset the radio station (see “Step 3: Presetting radio stations”) and set the clock (see “Step 2: Setting the time”) beforehand.

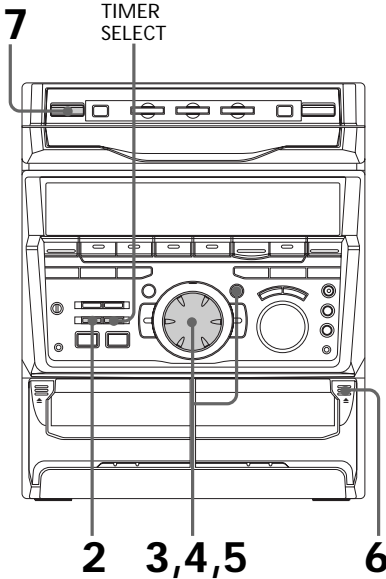

- 1 Tune in the preset radio station (see “Listening to the radio”).
- 2 Press CLOCK/TIMER SET. “SET DAILY 1” appears.
- 3 Turn jog dial to select “REC”, then press ENTER/NEXT. “ON” appears and the hour digits flash in the display.

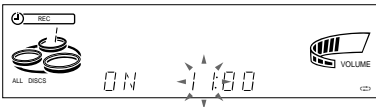

- 4 Set the time to start recording. Turn the jog dial to set the hour, then press ENTER/NEXT. The minute indication starts flashing.

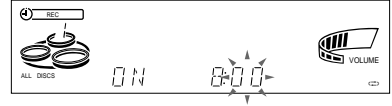

Turn the jog dial to set the minute, then press ENTER/NEXT. The hour indication flashes again.

- 5 Set the time to stop recording following the above procedure. The start time appears, followed by the stop time, the preset radio station to be recorded (e.g., “TUNER FM 5”), then the original display appears.
- 6 Insert a recordable tape.
- 7 Turn off the power. When the recording starts, the volume level is set to the minimum.

To check the setting

Press TIMER SELECT and turn the jog dial to select “REC”, then press ENTER/NEXT. To change the setting, start over from step 1.

To cancel the timer operation

Press TIMER SELECT and turn the jog dial to select “TIMER OFF”, then press ENTER/NEXT.

Note

If the power is on at the preset time, the recording will not be made.

Connecting audio components

Select one of the following two connections, depending on the equipment to be connected and method of connecting. Refer to the instructions of each component.

Connecting an MD deck for digital recording

You can record from CD into the MD deck digitally by connecting an optical cable.

To the DIGITAL IN jack of the MD deck

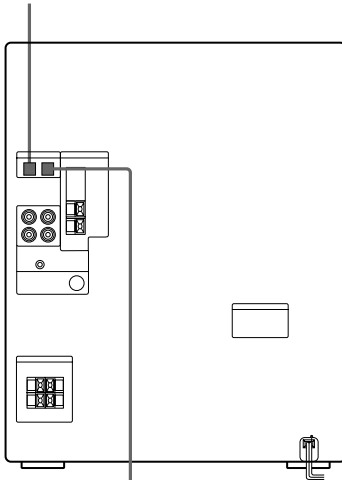

Optical Cover Holder

Tip

Keep the optical cover at the slot provided.

Connecting an MD deck for analog recording

Make sure to match the color of the plugs and the connectors. To listen to the sound of the connected MD deck, press FUNCTION repeatedly until "MD" appears.

To the audio output of the MD deck To the audio input of the MD deck

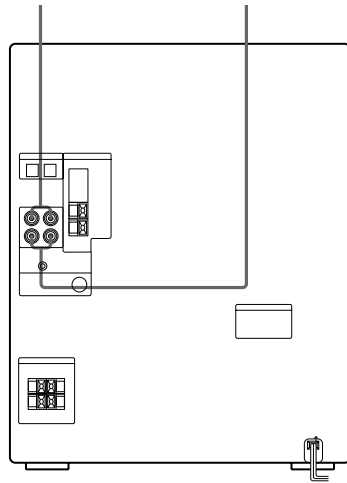

Tip

When you connect a Sony MD deck, you can use the MD ►, ||, and ■ buttons on this unit's remote to perform play, pause, and stop operations.

Note

If you cannot select "MD" even when you have pressed FUNCTION, press | / ⏻ while holding down FUNCTION when the power is turned off. "VIDEO" will be switched to "MD". To return to "VIDEO" do the same procedure.

continued

Connecting audio components (continued)

Connecting a super woofer speaker

(except for European model)

You can connect an optional super woofer speaker.

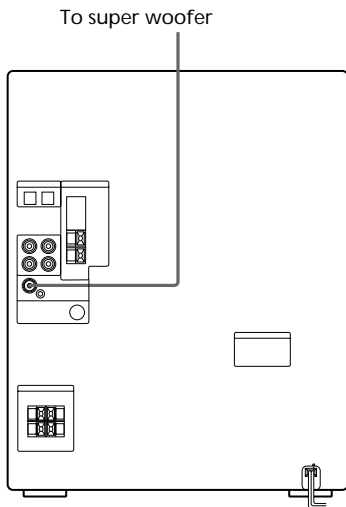

Note

If you have connected a super woofer, please note that sound comes from the super woofer even when the headphones are connected. Turn off the power of the super woofer when using headphones.

Connecting a VCR

Make sure to match the color of the plugs and the connectors. To listen to the sound of the connected VCR, hold down FUNCTION and press | / ⏻ when the power is turned off. This switches the "MD" function to "VIDEO". Once you enable the "VIDEO" function, just press FUNCTION repeatedly until "VIDEO" appears.

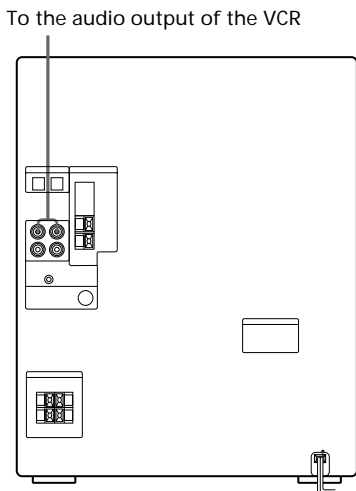

Note

If the sound is distorted or too loud when selecting "VIDEO", or you want to switch back to "MD", repeat the operation described above for switching to "MD".

Connecting external antennas

Connect the external antenna to improve the reception.

FM antenna

Connect the optional FM external antenna. You can also use the TV antenna instead.

Jack type Ⓐ

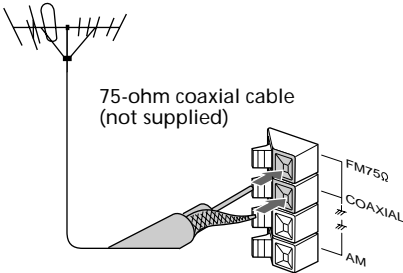

Jack type Ⓑ

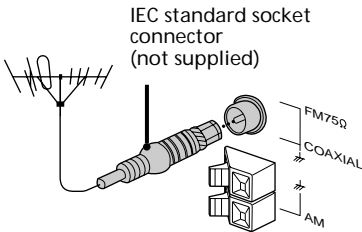

AM antenna

Connect a 6- to 15- meter (20- to 50- feet) insulated wire to the AM antenna terminal. Leave the supplied AM loop antenna connected.

Jack type Ⓐ

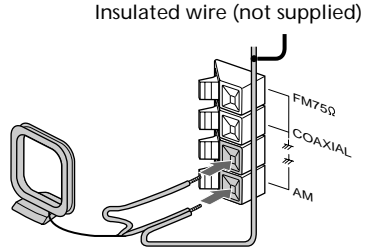

Jack type Ⓑ

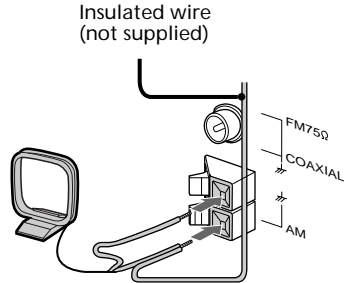

Precautions

On operating voltage

Before operating the unit, check that the operating voltage of your unit is identical with the voltage of your local power supply.

On safety

- The unit is not disconnected from the AC power source (mains) as long as it is connected to the wall outlet, even if the unit itself has been turned off.
- Unplug the unit from the wall outlet (mains) if it is not to be used for an extended period of time. To disconnect the cord (mains lead), pull it out by the plug. Never pull the cord itself.
- Should any solid object or liquid fall into the component, unplug the unit and have the component checked by qualified personnel before operating it any further.
- The AC power cord must be changed only at the qualified service shop.

On placement

- Place the unit in a location with adequate ventilation to prevent heat build-up in the unit.
- Do not place the unit in an inclined position.
- Do not place the unit in locations where it is:
 - Extremely hot or cold
 - Dusty or dirty
 - Very humid
 - Vibrating
 - Subject to direct sunlight

On operation

- If the unit is brought directly from a cold to a warm location, or is placed in a very damp room, moisture may condense on the lens inside the CD player. Should this occur, the unit will not operate properly. Remove the CD and leave the unit turned on for about an hour until the moisture evaporates.
- When you move the unit, take out any discs.

If you have any questions or problems concerning your unit, please consult your nearest Sony dealer.

Notes on CDs

- Before playing, clean the CD with a cleaning cloth. Wipe the CD from the center out.
- Do not use solvents such as benzene, thinner, commercially available cleaners or anti-static spray intended for vinyl LPs.
- Do not expose the CD to direct sunlight or heat sources such as hot air ducts, nor leave it in a car parked in direct sunlight.

Cleaning the cabinet

Use a soft cloth slightly moistened with mild detergent solution.

To save a tape permanently

To prevent a tape from being accidentally recorded over, break off the cassette tab from side A or B as illustrated.

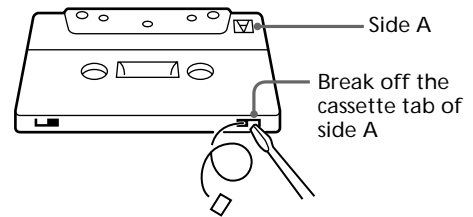
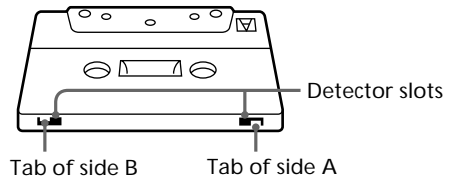

If you later want to reuse the tape for recording, cover the broken tab with adhesive tape. However, be careful not to cover the detector slots which allow the tape player to automatically detect the type of tape.

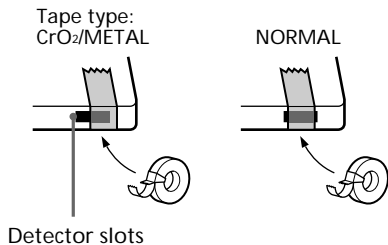

Before placing a cassette in the tape deck

Take up any slack in the tape. Otherwise the tape may get entangled in the parts of the tape deck and become damaged.

When using a tape longer than 90 minutes

The tape is very elastic. Do not change the tape operations such as play, stop, and fast-winding etc. frequently. The tape may get entangled in the tape deck.

Cleaning the tape heads

Clean the tape heads after every 10 hours of use.

When the tape heads become dirty;

- the sound is distorted
- there is a decrease in sound level
- the sound drops out
- the tape does not erase completely
- the tape does not record

Make sure to clean the tape heads before you start an important recording or after playing an old tape. Use separately sold dry-type or wet-type cleaning cassette. For details, refer to the instructions of the cleaning cassette.

Demagnetizing the tape heads

Demagnetize the tape heads and the metal parts that have contact with the tape every 20 to 30 hours of use with a separately sold demagnetizing cassette. For details, refer to the instructions of the demagnetizing cassette.

Troubleshooting

If you run into any problem using this unit, use the following check list.

First, check that the power cord is connected firmly and the speakers are connected correctly and firmly.

Should any problem persist, consult your nearest Sony dealer.

General

The display starts flashing as soon as you plug in the power cord even though you haven't turned on the power (demonstration mode).

- For MHC-RXD5/R550:
Press DISPLAY when the power is turned off. If the unit is in the Power Saving Mode, press POWER SAVE/ DEMO (STANDBY).
- For MHC-GRX30/GRX30J:
Press DEMO (STANDBY) when the power is turned off.

The demonstration mode appears automatically the first time you plug in the power cord or if there is a power outage.

The clock setting is canceled.

- The power cord is disconnected or a power failure occurs. Redo "Step 2: Setting the time". If you have set the timer, also redo "Waking up to music" and "Timer-recording radio programs".

The radio presetting/timer setting is canceled.

- The power cord is disconnected or a power failure occurs for longer than half a day. Redo "Step 3: Presetting radio stations".

There is no sound.

- Rotate VOLUME clockwise.
- The headphones are connected.
- Insert only the stripped portion of the speaker cord into the SPEAKER jack. Inserting the vinyl portion of the speaker cord will obstruct the speaker connections.

continued

Troubleshooting (continued)

- The protective device on the amplifier has been activated because of short circuit. (“PROTECT” and “PUSH POWER” flash alternately.) Turn off the unit, eliminate the short-circuit problem and turn on the power again.
- There is no audio output during timer recording.

There is severe hum or noise.

- A TV or VCR is placed too close to the stereo system. Move the stereo system away from the TV or VCR.

The sound from the connected source is distorted.

- If “VIDEO” appears in the display when you press FUNCTION, switch the display to “MD” (see “Note: Connecting a VCR”).

“0:00” (or “12:00”) flashes in the display.

- A power interruption occurred. Set the clock and timer settings again.

The timer does not function.

- Set the clock correctly.

DAILY 1, DAILY 2, and REC do not appear when you press the TIMER SELECT button.

- Set the timer correctly.
- Set the clock.

The remote does not function.

- There is an obstacle between the remote and the system.
- The remote is not pointing in the direction of the system’s sensor.
- The batteries have run down. Replace the batteries.

There is acoustic feedback.

- Decrease the volume level.
- Move the microphone away from the speakers or change the direction of the microphone.

The color irregularity on a TV screen persists.

- Turn off the TV set once, then turn it on after 15 to 30 minutes. If the color irregularity still persists, place the speakers farther away from the TV set.

“PROTECT” and “PUSH POWER” appear alternately.

- A strong signal was input. Press | / ⏻ to turn off the power, leave the system turned off for a while, then press | / ⏻ again to turn on the power.

Speakers

Sound comes from one channel or unbalanced left and right volume.

- Check the speaker connection and speaker placement.

Sound lacks bass.

- Check that the speaker’s + and – jacks are connected correctly.

CD Player

The CD tray does not close.

- The CD is not placed properly.

The CD will not play.

- The CD is not lying flat in the disc tray.
- The CD is dirty.
- The CD is inserted label side down.
- Moisture condensation has built up. Remove the CD and leave the system turned on for about an hour until the moisture evaporates.

Play does not start from the first track.

- The player is in program or shuffle mode. Press PLAY MODE repeatedly until “PROGRAM” or “SHUFFLE” disappears.

“OVER” is displayed.

- You have reached the end of the CD. Press and hold ◀◀ to return.

Tape Deck

The tape does not record.

- No tape in the cassette holder.
- The tab has been removed from the cassette (see “To save a tape permanently” on page 40).
- The tape has reeled to the end.

The tape does not record nor play or there is a decrease in sound level.

- The heads are dirty. Clean them (see “Cleaning the tape heads” on page 41).
- The record/playback heads are magnetized. Demagnetize them (see “Demagnetizing the tape heads” on page 41).

The tape does not erase completely.

- The record/playback heads are magnetized. Demagnetize them (see “Demagnetizing the tape heads” on page 41).

There is excessive wow or flutter, or the sound drops out.

- The capstans or pinch rollers are dirty. Clean them (see “Cleaning the tape heads” on page 41).

Noise increases or the high frequencies are erased.

- The record/playback heads are magnetized. Demagnetize them (see “Demagnetizing the tape heads” on page 41).

After pressing **▶** (**◀**) or **▲**, there is a mechanical noise, “EJECT” appears in the display, and the unit enters standby mode automatically.

- The cassette tape was not inserted correctly. Eject the tape and turn the power back on.
-

Tuner

Severe hum or noise (“TUNED” or “STEREO” flashes in the display).

- Adjust the antenna.
- The signal strength is too weak. Connect the external antenna.

A stereo FM program cannot be received in stereo.

- Press REPEAT STEREO/MONO so that “MONO” disappears.
-

If other troubles not described above occur, reset the system as follows:

- 1 Unplug the power cord.
- 2 Plug the power cord back in.
- 3 Press **■**, ENTER/NEXT, and **| / ⏻** at the same time.
- 4 Press **| / ⏻** to turn on the power.

The unit is reset to factory settings. All the settings you made, such as the preset stations, clock, and timer are cleared. You should set them again.

Specifications

AUDIO POWER SPECIFICATIONS: (USA models only)

POWER OUTPUT AND TOTAL HARMONIC DISTORTION

with 6 ohm loads both channels driven, from 70-20,000 Hz; rates 60 watts per channel minimum RMS power, with no more than 0.9% total harmonic distortion from 250 milliwatts to rated output.

Amplifier section

Canadian model:

Continuous RMS power output (reference)
60 + 60 watts
(6 ohms at 1 kHz,
10% THD)
Total harmonic distortion less than 0.07%
(6 ohms at 1 kHz, 30 W)

European model:

DIN power output (rated) 60 + 60 watts
(6 ohms at 1 kHz, DIN)
Continuous RMS power output (reference)
80 + 80 watts
(6 ohms at 1 kHz,
10% THD)
Music power output (reference)
140 + 140 watts
(6 ohms at 1 kHz,
10% THD)

Other models:

The following measured at AC 110, 220 V 50/60 Hz
DIN power output (rated) 60 + 60 watts
(6 ohms at 1 kHz, DIN)
Continuous RMS power output (reference)
80 + 80 watts
(6 ohms at 1 kHz,
10% THD)
The following measured at AC 120, 240 V 50/60 Hz
DIN power output (rated) 70 + 70 watts
(6 ohms at 1 kHz, DIN)
Continuous RMS power output (reference)
100 + 100 watts
(6 ohms at 1 kHz,
10% THD)

Inputs

MD/VIDEO (AUDIO) IN: voltage 450 mV/250 mV,
(phono jacks) impedance 47 kilohms
MIX MIC: sensitivity 1 mV,
(phone jack) impedance 10 kilohms

Outputs

MD/VIDEO (AUDIO) OUT:
(phono jacks) voltage 250 mV
impedance 1 kilohms
PHONES:
(stereo mini jack) accepts headphones of 8
ohms or more
SPEAKER:
accepts impedance of 6 to
16 ohms
SUPER WOOFER (except for European model):
voltage 1V, impedance
1 kilohm

CD player section

System Compact disc and digital
audio system
Laser Semiconductor laser
($\lambda=780\text{nm}$)
Emission duration:
continuous
Laser output Max. 44.6 μW^*
*This output is the value
measured at a distance of
200 mm from the
objective lens surface on
the Optical Pick-up Block
with 7 mm aperture.
Frequency response 2 Hz - 20 kHz (± 0.5 dB)
Wavelength 780 - 790 nm
Signal-to-noise ratio More than 90 dB
Dynamic range More than 90 dB
CD OPTICAL DIGITAL OUT
(Square optical connector jack, rear panel)
Wavelength 660 nm
Output Level -18 dBm

Tape player section

Recording system 4-track 2-channel stereo
Frequency response 40 - 13,000 Hz (± 3 dB),
(DOLBY NR OFF) using Sony TYPE I
cassette
40 - 14,000 Hz (± 3 dB),
using Sony TYPE II
cassette
Wow and flutter $\pm 0.15\%$ W.Peak (IEC)
0.1% W.RMS (NAB)
 $\pm 0.2\%$ W.Peak (DIN)

Tuner section

FM stereo, FM/AM superheterodyne tuner

FM tuner section

Tuning range 87.5 - 108.0 MHz
Antenna FM lead antenna
Antenna terminals 75 ohm unbalanced
Intermediate frequency 10.7 MHz

AM tuner section

Tuning range

2 Band type:

North American models: 530 – 1,710 kHz
(with the interval set at 10 kHz)

531 – 1,710 kHz
(with the interval set at 9 kHz)

European models: 531 – 1,602 kHz
(with the interval set at 9 kHz)

Other models: 531 – 1,602 kHz
(with the interval set at 9 kHz)
530 – 1,710 kHz
(with the interval set at 10 kHz)

3 Band type:

Middle Eastern models:

MW: 531 – 1,602 kHz
(with the interval set at 9 kHz)

SW: 5.95 – 17.90 MHz
(with the interval set at 5 kHz)

Other models:

MW: 531 – 1,602 kHz
(with the interval set at 9 kHz)
530 – 1,710 kHz
(with the interval set at 10 kHz)

SW: 5.95 – 17.90 MHz
(with the interval set at 5 kHz)

Antenna AM loop antenna
Antenna terminals External antenna terminal
Intermediate frequency 450 kHz

Speaker

SS-RXD5S for MHC-RXD5 (European model)

SS-R550 for MHC-R550 (European model)

Speaker system 3-way, 3-unit,
bass-reflex type

Speaker units

Woofer: 17 cm, cone type

Tweeter: 5 cm, cone type

Super Tweeter: 2 cm, dome type

Nominal impedance 6 ohms

Dimensions (w/h/d) Approx. 220 x 340 x 280 mm (8⁵/₈ x 13³/₈ x 11 in.)

Mass Approx. 4.0 kg net per speaker (8 lb. 10 oz.)

SS-RXD5 for MHC-RXD5 (North American model)

SS-GRX30 for MHC-GRX30

SS-GRX30G for MHC-GRX30 (Middle Eastern model)

SS-GRX30J for MHC-GRX30J

Speaker system 3-way, 3-unit,
bass-reflex type

Speaker units

Woofer: 15 cm, cone type

Center Tweeter: 5 cm, cone type

Super Tweeter: 2 cm, ceramic type

Nominal impedance 6 ohms

Dimensions (w/h/d) Approx. 220 x 340 x 265 mm

(8⁵/₈ x 13³/₈ x 10⁷/₁₆ in.)

Mass Approx. 3.8 kg net per speaker (8 lb. 4 oz.)

General

Power requirements

North American models: 120 V AC, 60 Hz

European models: 230 V AC, 50/60 Hz

Australian models: 230 - 240 V AC, 50/60 Hz

Mexican models: 120 V AC, 50/60 Hz

Thailand models: 220 - 240 V AC, 50/60 Hz

Other models: 110 - 120 V or 220 - 240 V AC, 50/60 Hz

Power consumption

U.S.A. models: 130 watts

Canadian model: 110 watts

European models: 130 watts

Other models: 110 watts

Dimensions (w/h/d) Approx. 280 x 340 x 380 mm (11 x 13³/₈ x 15 in.)

Mass : Approx. 9.5 kg (21 lb.)

Supplied accessories: AM loop antenna (1)
Remote commander (1)
Batteries (2)
FM lead antenna (1)
Front speaker pads (8)
Speaker cords (2) (for European model only)

Design and specifications are subject to change without notice.

Index

A

- Adjusting
 - the audio emphasis 28
 - the sound 27
 - the volume 11, 13, 16
- Antennas 5, 39
- Automatic Source Selection 11, 14, 16

B

- Batteries 6

C

- CD player 10, 18
- CD Synchro Recording 12
- Clock setting 6
- Connecting. *See* Hooking up

D

- Daily Timer 34
- Display 18, 29

E

- Edit 24

F, G

- Flash 26

H, I, J

- Hooking up
 - optional components 37
 - the antennas 5, 39
 - the power 5
 - the speakers 4
 - the system 4

K

- Karaoke 32

L, M

- Loop 26

N

- Normal Play 10
- Non-Stop Play 22

O

- One Touch Play 11, 14, 16

P, Q

- Playing
 - a CD 10
 - a preset radio station 13
 - tracks in random order (Shuffle Play) 20
 - a tape 15
 - tracks in the desired order (Program Play) 21
 - tracks repeatedly (Repeat Play) 19
- Presetting radio stations 7
- Preset Tuning 13
- Program Edit 24
- Program Play 21
- Protecting recordings 40
- PTY 30

R

- Radio Data System 30
- Radio stations
 - presetting 7
 - tuning in 13
- Recording
 - a CD 12, 24
 - a radio program 14
 - a tape 17, 23
 - timer recording 36
- Repeat Play 19
- Resetting the system 43

S

- Saving recordings 40
- Selecting the audio emphasis 28
- Setting the time 6
- Shuffle Play 20
- Sleep Timer 34
- Sound adjustment 27
- Speakers 4, 38
- Station name 31

T, U, V, W, X, Y, Z

- Tape deck 15, 23
- Timer
 - falling asleep to music 34
 - timer recording 36
 - waking up to music 34
- Troubleshooting 41
- Tuner 7, 13
- Tuning interval 8, 44

