

# FM/MW/LW Compact Disc Player

Installation/Connections

安裝／線路連接

CDX-MP30

Sony Corporation © 2002 Printed in Korea

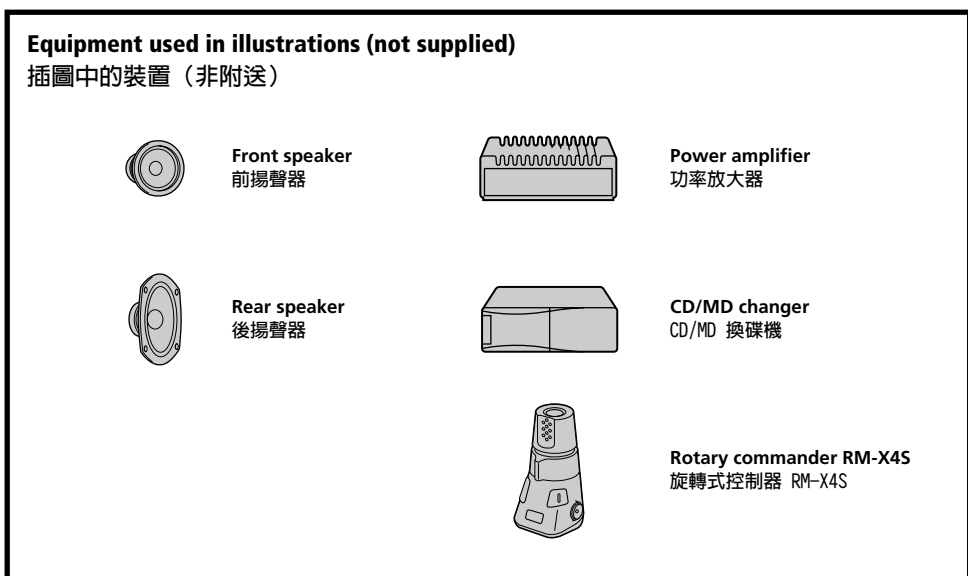
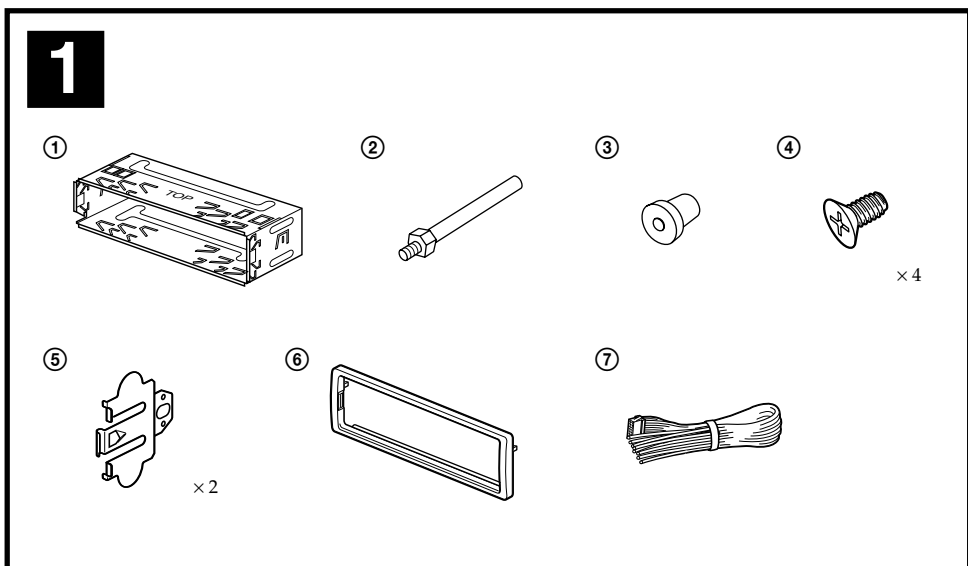
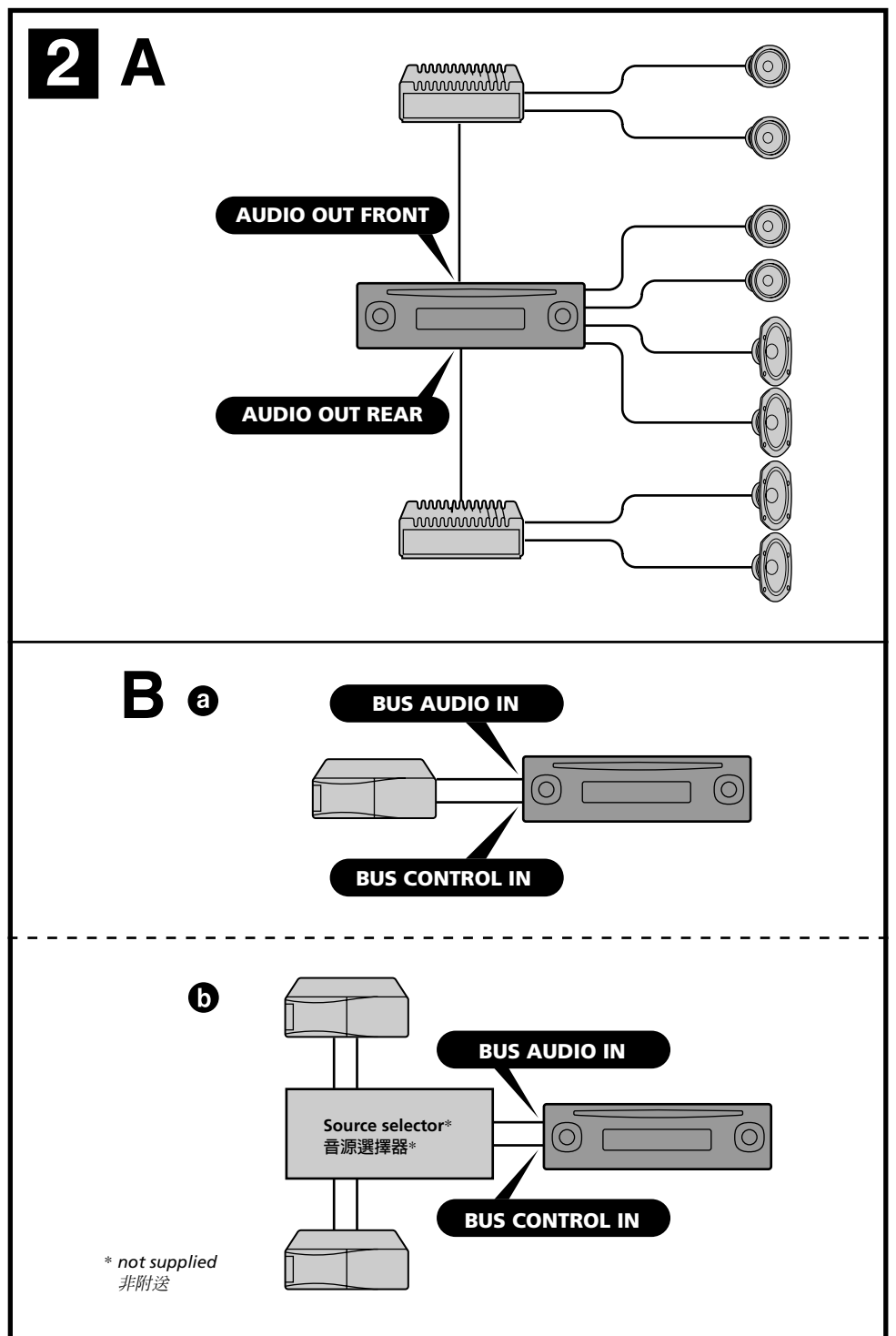

## Cautions

- This unit is designed for negative earth 12 V DC operation only.
- Do not get the wires under a screw, or caught in moving parts (e.g. seat railing).
- Before making connections, turn the car ignition off to avoid short circuits.
- Connect the **yellow** and **red** power input leads only after all other leads have been connected.
- **Run all earth wires to a common earth point.**
- Be sure to insulate any loose unconnected wires with electrical tape for safety.

## Notes on the power supply cord (yellow)

- When connecting this unit in combination with other stereo components, the connected car circuit's rating must be higher than the sum of each component's fuse.
- When no car circuits are rated high enough, connect the unit directly to the battery.

## Parts list (1)

The numbers in the list are keyed to those in the instructions.

## Caution

Handle the bracket ① carefully to avoid injuring your fingers.

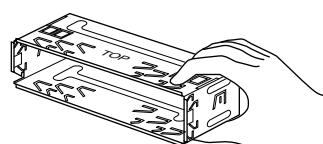

## Connection example (2)

### Notes (2-A)

- Be sure to connect the earth cord before connecting the amplifier.
- If you connect an optional power amplifier and do not use the built-in amplifier, the beep sound will be deactivated.

### Tip (2-B-0)

For connecting two or more CD/MD changers, the source selector XA-C30 (optional) is necessary.

## Connection diagram (3)

- To a metal surface of the car**  
First connect the black earth lead, then connect the yellow and red power input leads.
- To the power aerial control lead or power supply lead of aerial booster amplifier**  
**Notes**
  - It is not necessary to connect this lead if there is no power aerial or aerial booster, or with a manually-operated telescopic aerial.
  - When your car has a built-in FM/MW/LW aerial in the rear/side glass, see "Notes on the control and power supply leads."
- To AMP REMOTE IN of an optional power amplifier**  
This connection is only for amplifiers. Connecting any other system may damage the unit.
- To the interface cable of a car telephone**
- To the +12 V power terminal which is energized in the accessory position of the ignition key switch**  
**Notes**
  - If there is no accessory position, connect to the +12 V power (battery) terminal which is energized at all times.  
Be sure to connect the black earth lead to it first.
  - When your car has a built-in FM/MW/LW aerial in the rear/side glass, see "Notes on the control and power supply leads."
- To the +12 V power terminal which is energized at all times**  
Be sure to connect the black earth lead to it first.

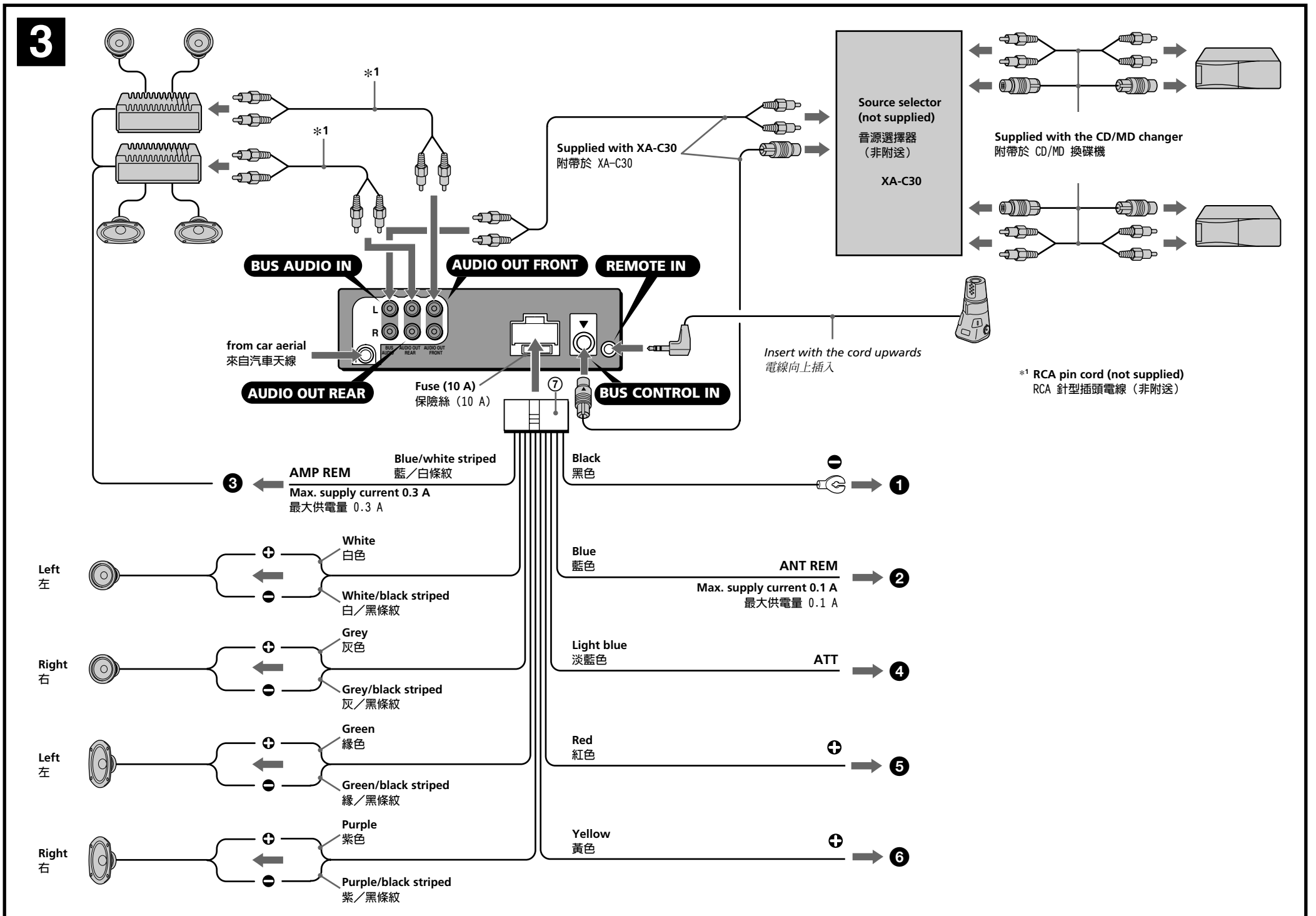

### Notes on the control and power supply leads

- The power aerial control lead (blue) supplies +12 V DC when you turn on the tuner or when you activate the AF (Alternative Frequency), TA (Traffic Announcement) function.
- When your car has built-in FM/MW/LW aerial in the rear/side glass, connect the power aerial control lead (blue) or the accessory power input lead (red) to the power terminal of the existing aerial booster. For details, consult your dealer.
- A power aerial without relay box cannot be used with this unit.

### Memory hold connection

When the yellow power input lead is connected, power will always be supplied to the memory circuit even when the ignition key is turned off.

### Notes on speaker connection

- Before connecting the speakers, turn the unit off.
- Use speakers with an impedance of 4 to 8 ohms, and with adequate power handling capacities to avoid its damage.
- Do not connect the speaker terminals to the car chassis, or connect the terminals of the right speakers with those of the left speaker.
- Do not connect the earth lead of this unit to the negative (-) terminal of the speaker.
- Do not attempt to connect the speakers in parallel.
- Connect only passive speakers. Connecting active speakers (with built-in amplifiers) to the speaker terminals may damage the unit.
- To avoid a malfunction, do not use the built-in speaker wires installed in your car if the unit shares a common negative (-) lead for the right and left speakers.
- Do not connect the unit's speaker cords to each other.

### 注意

- 本機只能使用負極接地 12 V 直流電源。
- 不要使導線夾在螺栓下，或繞掛在移動部件上（如：座椅扶手上）。
- 進行連接之前，請先關閉汽車的點火器，以避免短路。
- 黃色和紅色電源輸入導線必須在所有其它導線都連接完畢以後才連接。
- 將所有地線都連接到同一接地點。
- 為了安全，請確認把沒有連接的導線用電器膠帶包紮進行絕緣。

### 電源導線須知（黃色）

- 將本機与其它立體聲裝置相連接時，所連接的汽車電路容量必須大於每個裝置保險絲容量的總和。
- 當汽車電路容量不夠大時，請將本機直接與電池相連接。

### 零件一覽表 (1)

圖示數字與說明書中的數字是一致的。

### 注意

移動裝卸支架 ① 時，請特別注意別傷到手指。

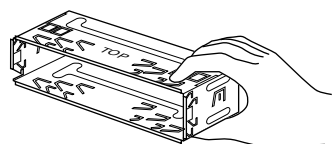

### 線路連接圖例 (2)

#### 註 (2-A)

- 務必在接放大器之前連接地線。
- 如果您連接了選購的功率放大器而不使用內裝的放大器，將無哪聲功能。

#### 要領 (2-B-b)

若要連接 2 台或更多 CD/MD 換碟機時，必須使用音源選擇器 XA-C30（選購件）。

### 控制和電源線須知

- 當您打開調諧器或啓動 AF（變換頻率）或 TA（交通公告）功能時，電源天線控制導線（藍色）提供 +12 V 直流電。
- 若您的汽車後/側玻璃窗上有內置 FM/MW/LW 天線，須將電動天線控制導線（藍色）或輔助電源輸入導線（紅色）連接到現有天線放大器上的電源端子上。詳細內容請向銷售商諮詢。
- 本機不能使用不具備繼電箱的電動天線。

### 保持記憶的線路連接法

當連接好黃色電源輸入導線時，即使汽車發動機點火鑰匙被轉在電源切斷之處，電源仍繼續將電流供給記憶電路，以保持所記憶著的數據。

### 連接揚聲器時的注意事項

- 連接揚聲器電線以前，請先切斷本機電源。
- 使用阻抗為 4-8 Ω 且具有充分功率處理容量的揚聲器，以免損壞揚聲器。
- 不要將揚聲器端子連接到汽車底盤上或將右揚聲器端子與左揚聲器端子相連接。
- 切勿將本機的接地導線連接到揚聲器的負(-)接線柱。
- 揚聲器不可以並聯連接。
- 請僅連接無源揚聲器。若將有源揚聲器（帶內置放大器）連接到揚聲器端子上會損壞本機。
- 若本裝置使用左、右揚聲器的共用(-)極導線，為了避免故障，切勿使用已安裝在汽車內的內置揚聲器導線。
- 請勿將本裝置揚聲器導線相互連接。

### 線路連接圖 (3)

- 至汽車的金屬部位  
首先連接黑色接地導線，然後再連接黃色和紅色電源輸入導線。
- 至電動天線控制導線或天線升壓放大器的電源導線  
註  
• 如無電動天線，天線增壓器，或用手操作的套管式天線，便不須連接此導線。  
• 您的汽車的後/側玻璃窗中如果內裝有 FM/MW/LW 天線，即請參看“控制和電源線須知”。
- 至選購的功率放大器的 AMP REMOTE IN（放大器遙控輸入）  
本連接僅用於放大器。連接任何其它系統可能會損壞本機。
- 至汽車電話的接口電纜
- 至在點火鑰匙的輔助位置上通電的 +12 V 電源端子  
註  
• 若沒有輔助位置，則請連接至常時通電的 +12 V 電源（電池）端子。  
務請首先將黑色接地導線與其連接。  
• 您的汽車的後/側玻璃窗中如果內裝有 FM/MW/LW 天線，即請參看“控制和電源線須知”。
- 至隨時都通電的 +12 V 電源端子  
務請首先將黑色接地導線與其連接。

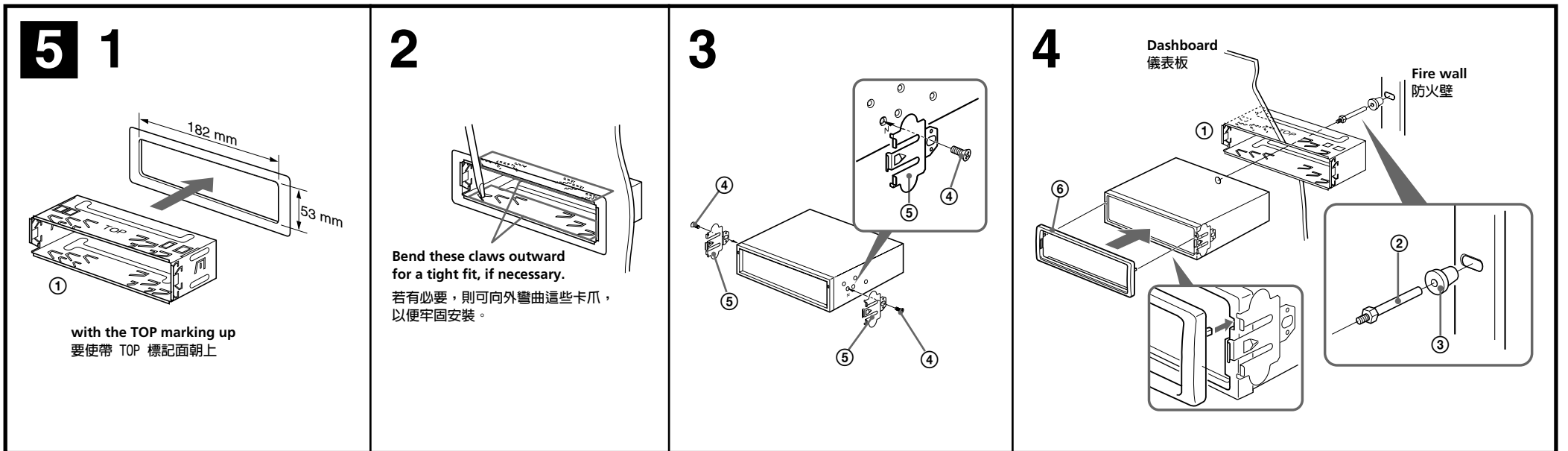
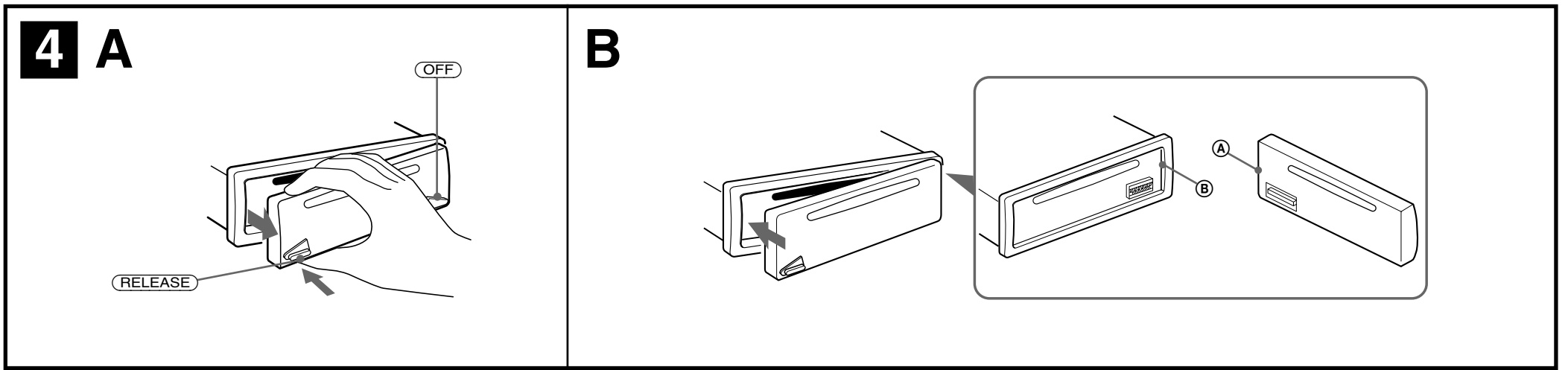

## Precautions

- Choose the installation location carefully so that the unit will not interfere with normal driving operations.
- Avoid installing the unit in areas subject to dust, dirt, excessive vibration, or high temperatures, such as in direct sunlight or near heater ducts.
- Use only the supplied mounting hardware for a safe and secure installation.

## Mounting angle adjustment

Adjust the mounting angle to less than 60°.

## How to detach and attach the front panel (4)

Before installing the unit, detach the front panel.

### 4-A To detach

Before detaching the front panel, be sure to press **OFF**. Press **RELEASE**, then pull it off towards you.

### 4-B To attach

Attach part **A** of the front panel to part **B** of the unit as illustrated and push the left side into position until it clicks.

## Mounting example (5)

Installation in the dashboard

## Mounting the unit in a Japanese car (6)

You may not be able to install this unit in some makes of Japanese cars. In such a case, consult your Sony dealer.

### Note

To prevent malfunction, install only with the supplied screws **④**.

## Warning when installing in a car without ACC (accessory) position on the ignition key switch

Be sure to press **OFF** on the unit for two seconds to turn off the clock display after turning off the engine.

When you press **OFF** only momentarily, the clock display does not turn off and this causes battery wear.

## RESET button

When the installation and connections are completed, be sure to press the RESET button with a ballpoint pen, etc., after removing the front panel.

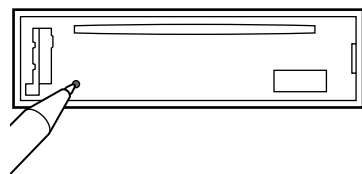

## 使用前注意事項

- 請仔細選擇安裝位置，以使本機不妨礙正常的駕駛操作。
- 避免將本機安裝在多塵、髒亂、極易受震動的地方，或者高溫之處，如陽光直射處或暖氣機前。
- 為了安全起見，安裝時請使用附送的部件。

## 安裝角度之調整

請在 60 度以內調整安裝角度。

## 如何拆卸和裝配前板 (4)

安裝本機之前，請先拆卸前板。

### 4-A 拆卸

拆卸前面板之前，須先按下 **OFF** 鍵。然後，按下 **RELEASE** 鍵，朝您自己的方向拉出。

### 4-B 裝配

如圖所示，將前板的 **A** 處對準本機的 **B** 處，然後將左側推入直至聽到喀噠聲。

## 安裝示例 (5)

安裝在儀錶板裡

## 將本機安裝於日本產汽車上時 (6)

有的日本產汽車不能安裝本機，在這種情形下，請您向當地的 Sony 經銷商諮詢。

### 註

為防止發生故障，安裝時只能使用附送的螺絲 **④**。

## 安裝在點火鑰匙開關上沒有 ACC (輔助) 位置的汽車上時的警告

在關掉汽車引擎之後，一定請按下機器上的 **OFF** 兩秒以關掉時鐘顯示。

如果只短暫地按一下 **OFF**，將不會關掉時鐘顯示而浪費電池。

## RESET 按鈕

當安裝和連接完成後，務請拆下前面板並用原子筆等按壓 RESET 按鈕。

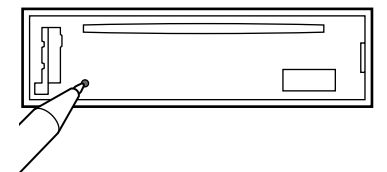

# 6 A TOYOTA

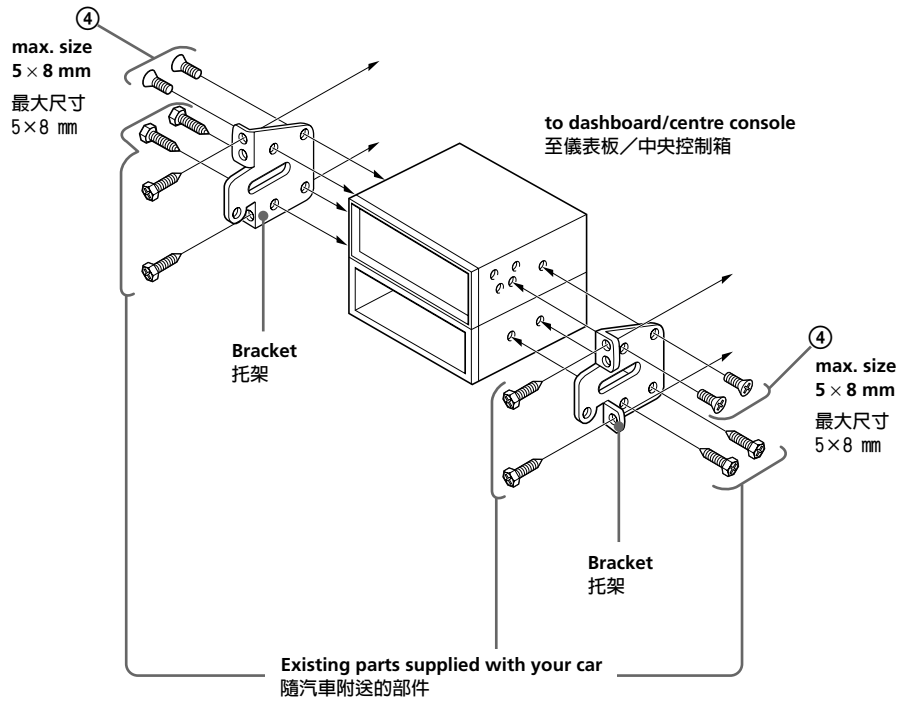

# B NISSAN

